



REPAIR MANUAL

**UX-450, 500 & 612 and
ALPHA-45, 50 & 60 Series
Pulse Unit Repair Manual**



Contents

	<u>Page Numbers</u>
1. Recommended Tools Needed for Repair	1
2. Pulse Unit Repair Fixtures	2-3
3. Disassembly & Reassembly of the Pulse Unit	4-7
4. Fill and Draw Sheet	8
5. Exploded View of the Pulse Unit	9-10
6. Recommended Maintenance	11

Recommended Tools Needed for Repair

1. 1 Set T-handle Metric Allen Wrenches
2. Flat-Bladed Screwdrivers
3. 10 oz. Ball Pin Hammer
4. 1 Set Pin Punches
5. 1 Set O-Ring Picks
6. 6" Adjustable End Wrench
7. 12" Adjustable End Wrench
8. Medium Pair Channel Locks or Adjustable Jaw Pliers
9. Medium Honing Stone
10. 220 Grit Wet/Dry Sandpaper
11. Lap Plate
12. Loc-Tite #242
13. CFC Free Degreaser-Cleanser
14. Loc-Tite Accelerator
15. Arbor Press
16. VC-101-2A Vacuum Tank
17. VCE-1-1 Vacuum Extractor
18. 1cc Glass Syringe
19. Large Needle For Syringe
20. Two Torque Wrenches 0-200 ft. lbs.
21. Universal Repair Fixture
22. Pulstar Pulse Unit Fluid
23. O-Ring Installation Tools
24. Removal of Air Motor Connector (UX-450 through UX-612)
25. UTA-204 and UMS/Joint Simulators UFT's
26. Needle Nose Pliers
27. Propane Torch
28. Teflon Seal Setter
29. Bearing Removal Jig
30. Bearing Setter

Pulse Unit Repair Fixtures

Jig for Setting Teflon Seal

Part Numbers	Tools Jig is Used With			
178-319-8-1	UX-450	UX-500	UX-612	
995-512-0-1	UX-622	ALPHA-50	ALPHA-60	
178-350-9-2	UX-450D	UX-500D	UX-612D	
995-512-0-1	UX-622D	ALPHA-50D	ALPHA-60D	
194-319-3-1	UX-T900	UX-T1000	UX-T1300	ALPHA-90
199-319-6-1	UX-T1620			
995-500-0-1	UXR-T2000			

Jig for Holding and Pressing in the Accumulator

Part Number	Tools Jig is Used With			
155-972-2-1	ALPHA-T45	ALPHA -T50	UBP-7	UBP-T7

Jig for Disassembly & Assembly of Casing Connector

Part Numbers	Tools Jig is Used With			
196-294-6-5	U-310SD			
192-035-4-5	U-350D	U-350SD		
177-036-6-5	UX-450 & ALPHA-60	UX-500 & ALPHA-T45	UX-612 & ALPHA-T50	ALPHA-50

Jig for Setting Torque Adjuster

Part Number	Tools Jig is Used With			
195-907-3-1	UX-1000	UX-1300	UX-1400	UX-1620

Vacuum Filler Tank

Part Number	Tools Jig is Used With
VC-101-2A	All Models

Glass Syringe

Part Numbers	Tools Jig is Used With
188-902-0-2 (1cc)	All Models
915-176-0 (3cc)	All Models
J17416GX3 (Needle)	All Models

Pulse Unit Repair Fixtures (cont.)

Pulse Unit Fluid

Part Numbers	Tools Jig is Used With
PULSTAR	All models except ALPHA-T45, T50, and UBP-7 Series
SPF-OIL	ALPHA-T45, T50, and UBP-7 Series only

Jig Set-In O-Ring

Part Numbers	Tools Jig is Used With			
990-319-0-1	U-310SD	U-350SD	U-350SD	UX-800
990-320-0-1	UX-500 UX-900	UX-620 UX-622	UX-620 UX-622	
990-320-2-1	UX-700			UX-1620
990-971-0-1	UXR-1000 UXR-1820	UX-1400	UX-1400	UXR-3000S
990-972-0-1	UXR-2000	UXR-2400S	UXR-2400S	UX-800

Jig for Placing Anvil C/W Driving Blades into Liner

Part Numbers	Tools Jig is Used With			
190-440-6-1 190-440-6-0	UX-500 UX-622	UX-602	UX-612	UX-620
194-440-2-1 194-440-2-0	UX-700	UX-800	UX-T700	UX-T800
194-440-3-1 194-440-3-0	UX-900	UX-T900		
194-440-6-1 194-440-6-0	UX-1000	UX-1300	UX-T1000	UX-T1300
195-440-6-1 195-440-6-0	UX-1400	UX-1620	UX-T1400	UX-T1620

Universal Pulse Unit Repair Fixture

Part Number	Tools Jig is Used With
PTRF-1-1	All Models

Vacuum Extractor

Part Number	Tools Jig is Used With
VCE-1-1	All Models

Disassembly / Reassembly of Pulse Unit

UX-450, 500, 612 & 622 ALPHA-50 & 60

Disassembly of Pulse Unit

1. Remove the front casing from the tool; all are left-hand thread except for the UX-622.
2. Turn the Torque Adjuster in until it stops and remove the Snap Ring from the front of the Pulse Unit by putting a pick behind the Snap Ring at the Torque Adjuster. Now remove the Torque Adjuster by turning it counter-clockwise.
3. Remove the Oil Fill Plug and vacuum the oil out of the Pulse Unit with the VCE-1-1 Vacuum Extractor.
4. Set the Liner Casing Setter, located at the rear of the Pulse Unit, onto the correct size pins in the blocks of the setter. **Note:** This is left-hand thread.
5. Place the Pulse Unit assembly onto the correct size base plate and between the clamp plates. Run the press rod down into the setter and secure it with the lock nut. It is not necessary to put any pressure on the press rod. Tighten the clamp screws thus securing the Pulse Unit.
6. Set a 1/2 inch breaker bar into the setter. This is a left-handed thread indicated by an arrow on the Liner Casing Setter.
7. Loosen and remove the Liner Casing Setter. Remove the Pulse Unit from the repair fixture.
8. Remove the Rear Liner Plate.
 - a) If suction is too great, tap the drive end of the Anvil on bench and loosen Rear Liner Plate.
 - b) Remove the two locator pins from the rear of Liner.
9. Rotate the Anvil until the bevel lines of the Anvil are parallel with the contacting lines inside the Liner. Push the Anvil and Driving Blades out of the Liner.
10. Remove the Front Liner Plate and Liner from the Liner Casing. **Note:** You may have to tap the rear of the Liner Casing on the bench top to remove the Front Liner Plate.
11. Remove the two Locator Pins in the front of the Liner.
12. Remove all O-rings and Supporter Rings from the parts. Remove the Anvil, O-ring or Teflon seal and Supporter ring, located inside the Liner Casing.

Inspection

1. **Front Liner Plate**
 - a) If light scarring on the plate surface is present, resurface on Lap Plate in a "figure eight motion" with 220 grit (wet or dry) sandpaper using honing oil as a buffer. **Note:** All markings must be removed.
 - b) If heavy scars or burring are present and cannot be resurfaced to a smooth finish, replace the part as needed.
2. **Rear Liner Plate**
 - a) Do not resurface this plate. There will be a seating mark from the Anvil and when this gets deeper than .05mm in depth, replace the part.

Disassembly / Reassembly of Pulse Unit (cont.)

3. **Liner Casing Setter**

- a) Wire wheel outer threads to remove old Loc-Tite.
- b) Resurface bottom setting surface (level) using Lap Plate and 220 grit sandpaper.

4. **Driving Blades**

- a) Check the contour surface of the blades for scars or burring.
- b) If driving blade is scarred below the contour surface, fluid will pass underneath the blade at contact points, resulting in inaccurate pressure in the liner and low torque output.
- c) If there is heavy scarring (cuts below contour surface) replace it.
- d) Light scarring on contour surface is normal wear. Clean surface of the Lap Plate by lapping the length of the blade and roll with the contour.
- e) A light horizontal groove on the side of the blade is normal wear.
- f) Check the plate ends of the blade for grooving. If heavy grooving, always replace the blades as a set.

5. **Liner**

- a) Inspect inner horizontal and vertical blade seats for scars and burring.
 1. Light scarring is normal wear.
 2. Heavy scars will cause the fluid to pass by the driving blade and the liner will not produce accurate pressure for torque output. Replace.

6. **Torque Adjuster**

- a) Check the adjuster for straightness and check the Allen end for cracking, damaged or stripped threads. If damage is present, replace.

7. **Liner Casing**

- a) Check for internal scars and burring.
- b) Check internal threads for burrs.

8. **Anvil**

- a) Check plate surface of Anvil. If light scarring or uneven wear is present, resurface with medium oil stone using honing oil as a buffer.
- b) If heavy scarring is present and cannot be resurfaced smooth, replace Anvil.
- c) If chips or cracking are present, replace Anvil.
- d) If uneven wear from socket is present, replace Anvil.
- e) Check Anvil at contact point with O-ring or Teflon Seal. If there is an indentation present on Anvil at this point, Anvil should be replaced.
- f) Check Anvil for scarring from Anvil bushing. If heavy scarring is present, replace Anvil.
 1. Thoroughly clean all parts and blow dry.
 2. Replace all O-rings, Springs, Supporter Rings, and Teflon seals. This can be easily done by purchasing a Pulse Unit Repair Kit.

Disassembly / Reassembly of Pulse Unit (cont.)

Reassembly

1. Using blow gun, clean parts of any remaining solvent or lint.
2. Install O-Rings and Supporter Rings onto Torque Adjuster and Oil Fill Screw.
3. Set the Rear Liner Plate onto a 6mm Allen wrench and install the two, short Locating Pins and the Liner.
Note: The Liner has no top or bottom.
4. Install Driving Blades and Springs into Anvil. Place in Driving Blade Setter.
5. Install Anvil and Driving Blades into Liner.
6. Install the two long Locating Pins into the Liner, and install the Front Liner Plate with the five holes down towards the Liner.
7. Install Rear Plate O-ring.
8. Install the Anvil Sleeve for the Teflon Seal. **Note:** There is an Anvil Sleeve for the 1/4 inch hex Anvil and the 3/8 inch square Anvil.
9. Using the Teflon Seal Insertion Tool, insert the Teflon Seal into the front of the Liner Casing on the UX-450, 500, and 612. Insert the O-Ring and Supporter Ring on the ALPHA-45, 50, and 60.
10. Install the Liner Casing making sure to line the holes in the Liner Casing with the Oil Fill Screw hole and Torque Adjuster hole in the Front Liner Plate.
11. Clean all oils from the threads of Liner Setter and Liner Casing. Lightly coat the threads with a good cleaner/degreaser. Put a light coat of a good quality thread locker on the threads of the Liner setter and thread it into the Liner Casing.
12. Set the Liner Casing Setter, located at the rear of the Pulse Unit, onto the correct size pins in the blocks of the setter. **Note:** This is left-hand thread.
13. Place Pulse Unit assembly onto the correct size base plate and between the clamp plates. Run the press rod down into the setter and secure it with the lock nut. It is not necessary to put any pressure on the press rod. Tighten the clamp screws securing the Pulse Unit.
14. Set a 1/2 inch torque wrench into the setter and tighten the Liner Setter to the recommended torque shown on the chart.
15. Remove the Pulse Unit from the repair fixture.

Fluid

1. Recommended fluid is AIM/Uryu Pulse Unit Fluid part number Pulstar.

Hand and Vacuum Tank Filling Procedure

1. Rotate the Anvil until the Driving Blade is visible in the Oil Filler Opening, then turn the Anvil 1/8 of a turn. This places the Driving Blades at an open position.
2. The Pulse Unit is now set for maximum fill. Any measurable change in fluid level will affect the torque output and the consistency of the tool.
3. Put the Pulse Unit in the Vacuum Tank to purge all air out of the Pulse Unit, proceed to step 7. If you do not have a vacuum tank, proceed to step 4.

Disassembly / Reassembly of Pulse Unit (cont.)

4. Fill the 3cc Syringe with fluid. Turn Syringe upside-down and push the plunger to purge all air from the Syringe.
5. Insert the Needle on the Syringe and insert it into the Oil fill hole. Fill the Pulse Unit completely with fluid from the bottom up, slowly.
6. Fill 1cc Syringe with fluid and again purge all air bubbles.
7. Remove the Pulse Unit from the Vacuum Tank.
8. Install the Torque Adjuster and the Snap Ring. Turn Torque Adjuster back up against the Snap Ring.
Note: This is the smaller of the two threaded holes.
9. Rotate Anvil until Driving Blade is again visible in Oil Filler Opening and turn Blade 1/8 of a turn from opening.
10. Fill 1cc Syringe with 0.5cc of fluid for accurate drawing of fluid.
11. Wipe off excess fluid from the top of the unit. The oil level should be at the top of the Oil Filler Plug Hole before drawing.
12. Using the 1cc Syringe, draw out the specified amount of fluid per specifications for each model (see chart).
13. Thread Oil Filler Plug into hole and tighten.
14. You are now ready to test the Pulse Unit.

Torque Adjustment

1. To properly adjust the torque: Turn the Adjuster clockwise using a 1.5mm Allen wrench until the Adjuster Valve bottoms-out then back off one turn (counter-clockwise) for maximum torque.
2. Reverse procedure for minimum torque. **Note:** Never leave the adjuster in the bottom-out position, as this will cause erratic torque and vibration.

Fill, Draw & Torque Sheet

Fill & Draw Sheet

Key Model of this Tool Group	Full Volume of Liner Oil in Pulse Unit (approx.)	Volume to be Removed from the Full Volume (approx.)	Torque to Tighten Liner Casing Setter (approx.)	Torque to Tighten Liner Casing Setter (approx.)	Load to Press on Rear Liner Plate	Load to Press on Rear Liner Plate
					Hydraulic Press	P.T.R.F.
Model	cc's	cc's	NM	Ft-Lbs	Tons	Ft-Lbs
U-300SD	5.0	0.15	50 +/-5	37		
U-310SD / U-50EC	5.0	0.15	50 +/-5	37		
U-350	5.0	0.15	50 +/-5	37		
U-410 / U-60EC	8.5	0.35	70 +/-5	52		
UX-450	5.0	0.35	70 +/-5	52		
U-480	9.0	0.40	70 +/-5	52	3	60
UX-500	5.0	0.35	70 +/-5	52		
U-501 / U-80EC	9.0	0.40	70 +/-5	52	3	60
ALPHA-45	5.0	0.45	70 +/-5	52		
ALPHA-50 / ALPHA-60MC	5.0	0.40	70 +/-5	52		
ALPHA-T45 & T50 / UBP-7	5.0		70 +/-5	52		
U-610	13.0	0.55	70 +/-5	52	3	60
U-610T	13.0	0.55	70 +/-5	52	3	60
UX-612	6.2	0.60	85 +/-5	63		
UX-622	6.2	0.60	85 +/-5	63		
ALPHA-60 / ALPHA-80MC	6.2	0.55	85 +/-5	63		
U-700 / U-100EC	18.0	0.90	70 +/-5	52	3	60
U-700T	18.0	0.90	70 +/-5	52	3	60
UX-700 / UX-80EC	8.8	0.80	110 +/-5	81	2	40
UX-T700	8.8	0.70	110 +/-5	81	2	40
UX-T700L	8.8	0.70	110 +/-5	81	2	40
ALPHA-70	8.8	0.90	110 +/-5	81	2	40
ALPHA-T70	8.8	0.80	110 +/-5	81	2	40
U-800	20.0	1.00	90 +/-5	67	3	60
U-800T	20.0	1.00	90 +/-5	67	3	60
UX-800	12.0	0.80	135 +/-5	100	2	40
UX-T800	12.0	0.80	135 +/-5	100	2	40
ALPHA-80 / ALPHA-100MC	12.0	1.10	135 +/-5	100	2	40
ALPHA-T80	12.0	0.80	135 +/-5	100	2	40
U-900	25.0	1.25	100 +/-5	74	3	60
U-900T	25.0	1.25	100 +/-5	74	3	60
UX-900 / UX-120EC	14.0	0.95	150 +/-5	110	3	60
UX-T900	14.0	0.95	150 +/-5	110	3	60
ALPHA-90	14.0	1.10	150 +/-5	110	3	60
ALPHA-T90	14.0	0.90	150 +/-5	110	3	60
U-1000	32.0	1.70	110 +/-5	81	3	60
U-1000T	32.0	1.70	110 +/-5	81	3	60
UX-1000 / UX-130EC	19.0	1.50	185 +/-10	137	3	60

Exploded View of the Pulse Unit

UX-450, 500 & 612 Pulse Unit

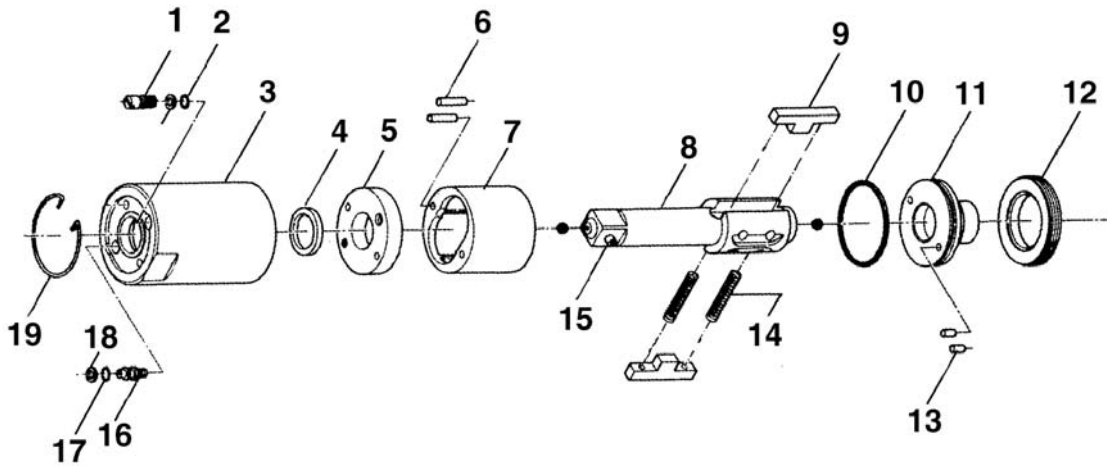

Part Number	Description	Part Number	Description
1	Oil Fill Plug	10	Rear Liner Plate O-ring
2	Oil Fill Plug O-ring	11	Rear Liner Plate
3	Liner Casing	12	Liner Casing Setter
4	Teflon Seal	13	Short Locator Pins
5	Front Liner Plate	14	Driving Blade Springs
6	Long Locator Pins	15	Retainer Pin Assembly
7	Liner	16	Relief Valve Spindle
8	Anvil	17	Relief Valve O-ring
9	Driving Blade	18	Relief Valve Supporter Ring
		19	Snap Ring

Exploded View of the Pulse Unit (cont.)

ALPHA-45, 50 & 60 Pulse Unit

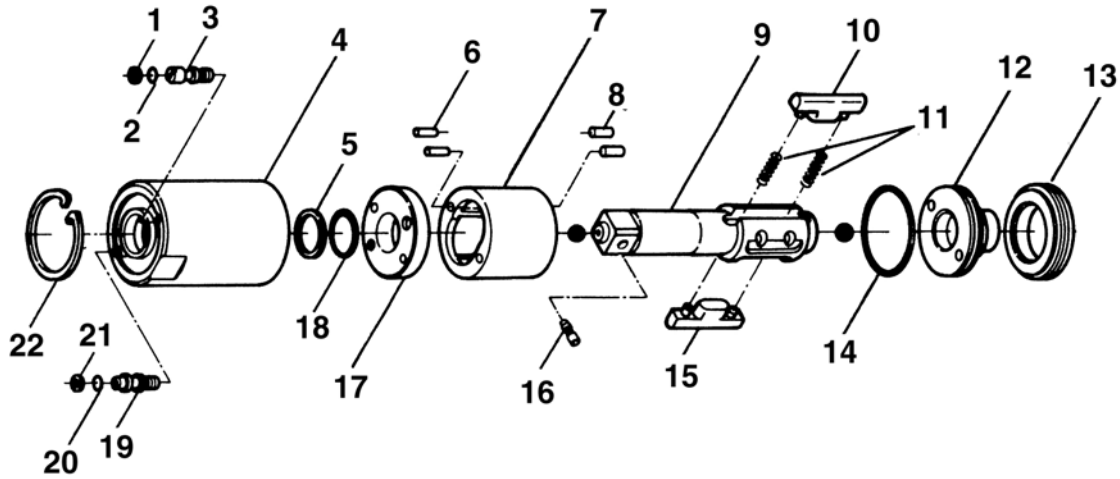

Part Number	Description	Part Number	Description
1	Oil Fill Plug Supporter Ring	12	Rear Liner Plate
2	Oil Fill Plug O-ring	13	Liner Casing Setter
3	Oil Fill Plug	14	Rear Liner Plate O-ring
4	Liner Casing	15	Driving Blade
5	Anvil Supporter Ring	16	Retainer Pin Assembly
6	Long Locator Pins	17	Front Liner Plate
7	Liner	18	Anvil O-ring
8	Short Locator Pins	19	Relief Valve Spindle
9	Anvil	20	Relief Valve O-ring
10	Driving Blade	21	Relief Valve Supporter Ring
11	Driving Blade Springs	22	Snap Ring

Recommended Maintenance

Pulse Unit

The Pulse Unit oil should be changed every 150,000 cycles. After 300,000 cycles, the Pulse Unit should be rebuilt and a repair kit installed. Remember to always use genuine Uryu parts and Pulstar Pulse Unit Fluid.