

Fastening Counter with Pokayoke

INSTRUCTION MANUAL AND THE SPECIFICATIONS

UTM-1100

Uryu Seisaku, Ltd.
2-11, 1-Chrome. Fukaeminami,
Higashinari, Osaka,
Japan

Contents

1. COVER PAGE
2. CONTENTS (THIS PAGE)
3. INTRODUCTION AND THE SPECIFICATIONS
4. AVAILABLE OPTIONS (A), (B) AND (C)
5. AVAILABLE OPTIONS (A), (B) AND (C)
6. FRONT AND REAR PANEL, COUNT DOWN AND WORK SELECT
7. OPTION (A)
8. PROGRAMMING AND LAY OUT PICTURES
9. PRESSURE SENSOR SETTING
10. PRESSURE SENSOR SETTING FOR OPTION (B)
11. PRESSURE SENSOR SETTING FOR OPTION (C)
12. FUNCTIONIONG POINT OF POKAYOKE AND THE NG REPAIRING
13. OTHER FUNCTIONS OF DIP SWITCHES, OK INDICATION, EXTRA SWITCH AND NG REPAIRING
14. WORK SELECT AND ERROR DISPLAY
15. BATTERY CHANGE

Fastening Counter with Pokayoke

IN AN ASSEMBLY LINE, IT IS A SERIOUS PROBLEM TO HAVE ANY WORK PASSED THROUGH WORKING STATION WITHOUT TIGHTENING OF TOTAL NUMBER OF FASTENERS.

USE OF YOUR FASTENING TOOLS WITH UTM-1100/UTM-1100 (RA) WILL ALLOW POKAYOKE TO BEGIN.

SELECT YOUR SUITABLE POKAYOKE FROM THE FOLLOWING COMBINATIONS.

SPECIFICATIONS

POWER SOURCE

AC100V, AC110V and AC230V

RANGE OF DISPLAY

Digital LED 1-99

CONTENTS OF DISPLAY

Number of fasteners or time of timer

JUDGEMENT

Green = Good and Red = NG with buzzer sounding

DIMENSIONS

210(W)X85(H)X200(D)

WEIGHT

about 2.5 kgs

Available Options (A), (B) and (C)

Combination		Count Down	Initial Trouble Detection	Cycle Error Detection
UTM-110 (A)	UX-T, UXR-T, ALPHA-T	YES	NO	NO
UTM-1100 (RA) (B)	UX-T (TM), UXR-T (TM)	YES	YES	YES
UTM-1100 (RA) (C)	U-(TM), UX-(TM), UXR-(TM), ALPHA-(TM), UW-(TM)	YES	YES	YES

OPTION (A)

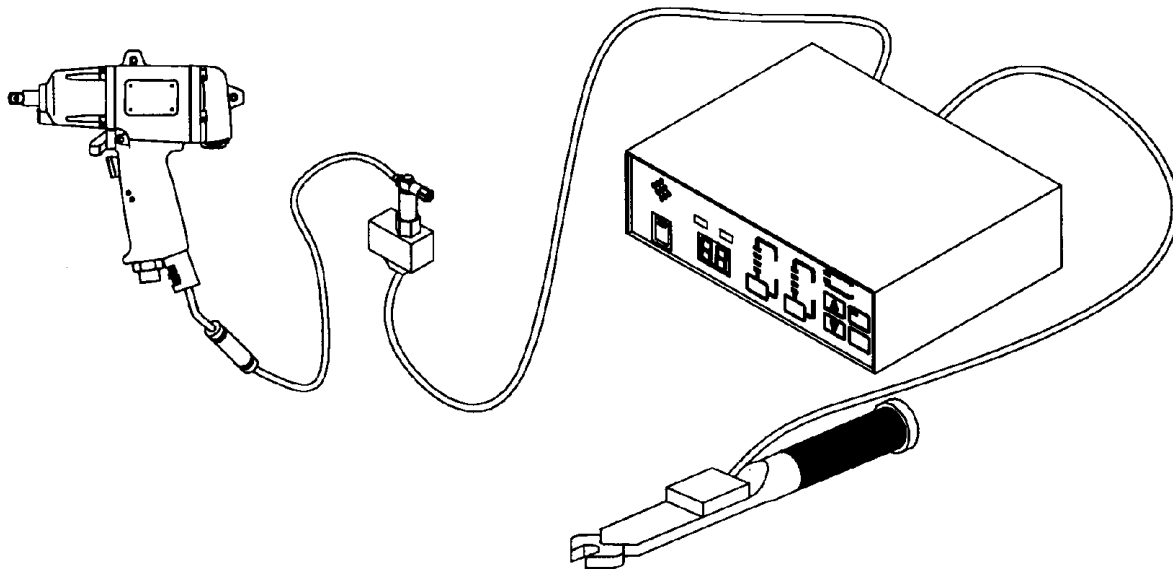

OPTION (B)

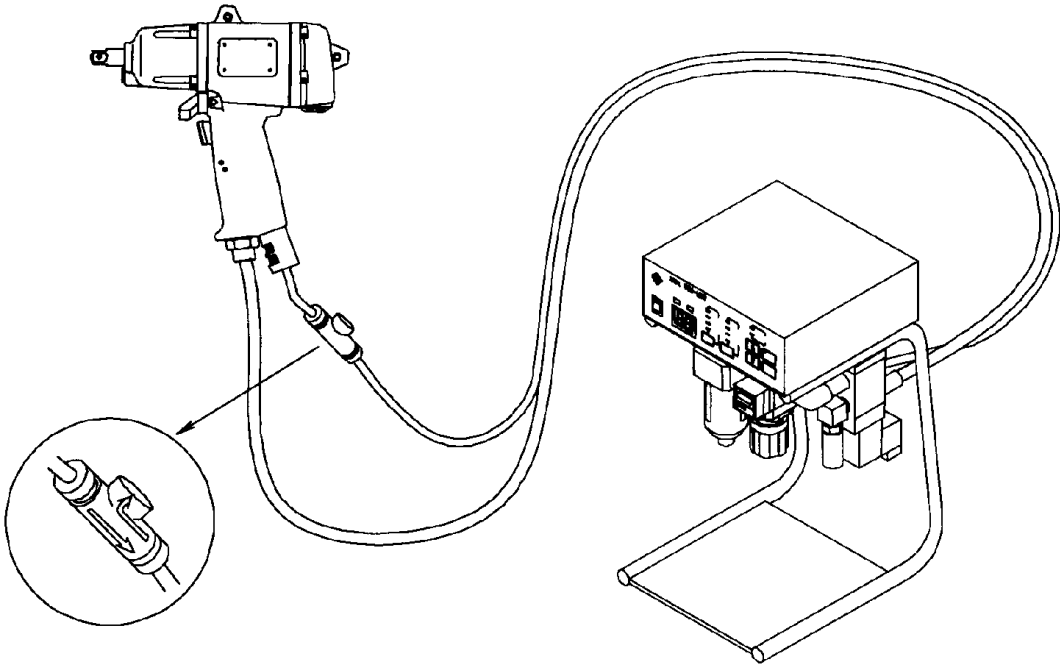

OPTION (C)

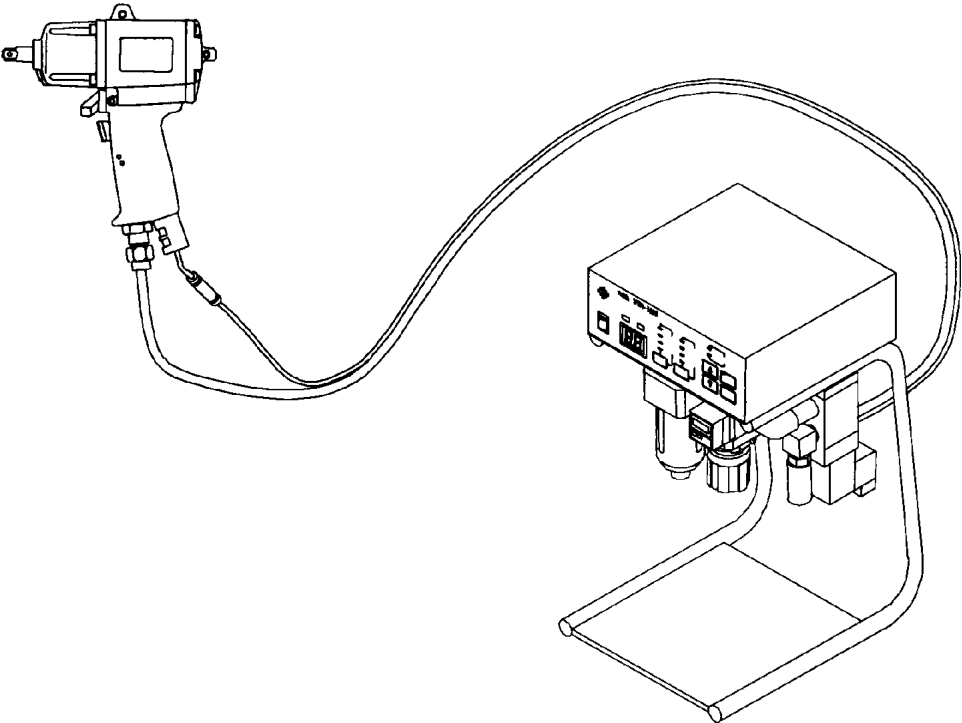

FRONT PANEL

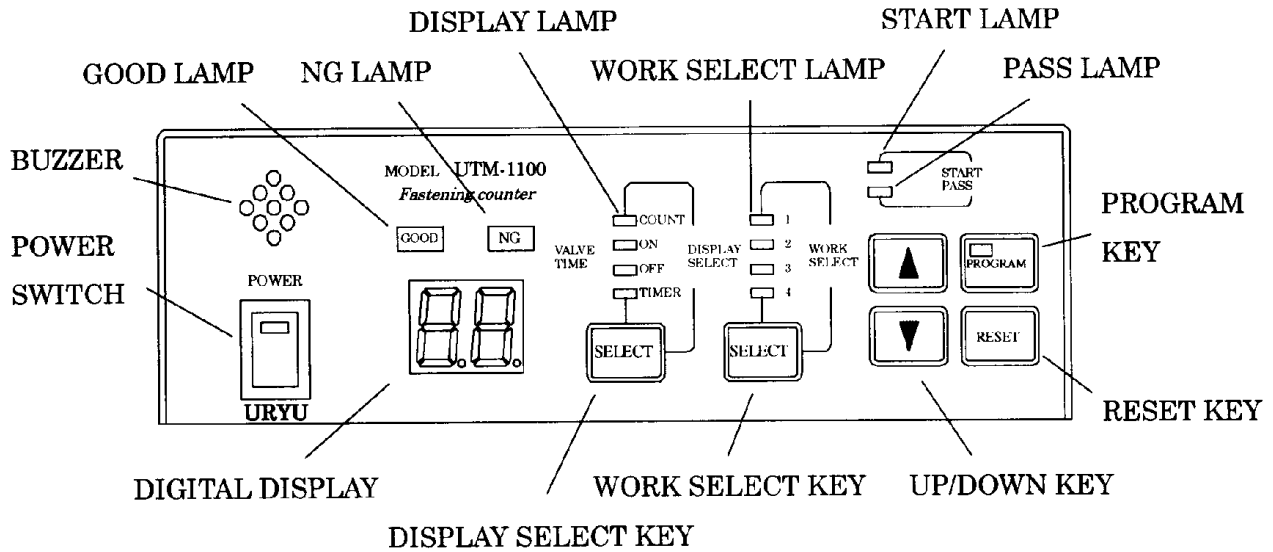

REAR PANEL

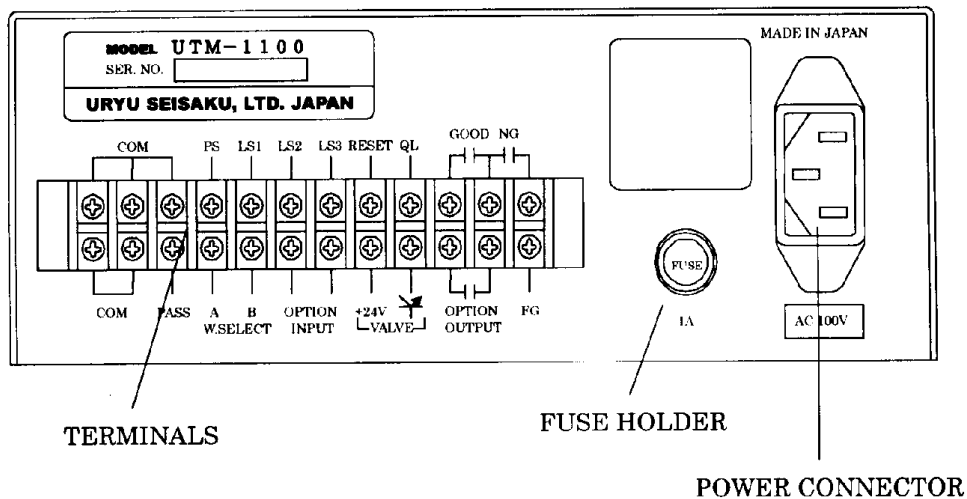

COUNT DOWN NUMBER & WORK SELECT SETTING

1. Turn on UTM-1100/UTM-1100(RA) and press PROGRAM KEY. A small green lamp of PROGRAM KEY will light and this allows programming to begin.
2. Press WORK SELECT KEY until necessary work number (1, 2, 3 or 4) is displayed on DIGITAL DISPLAY.
3. Press UP/DOWN KEY to have number of fasteners, Δ increase or ∇ decrease.
4. Press RESET KEY or PROGRAM KEY to input above programming and the small lamp of PROGRAM KEY will go off. Number of fasteners have been inputted.

OPTION (A): UTM-1100 & UX-T(TM)/UXR-T(TM)/ALPHA-T(TM)

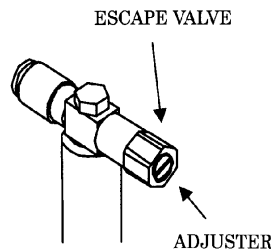
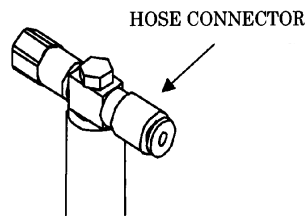
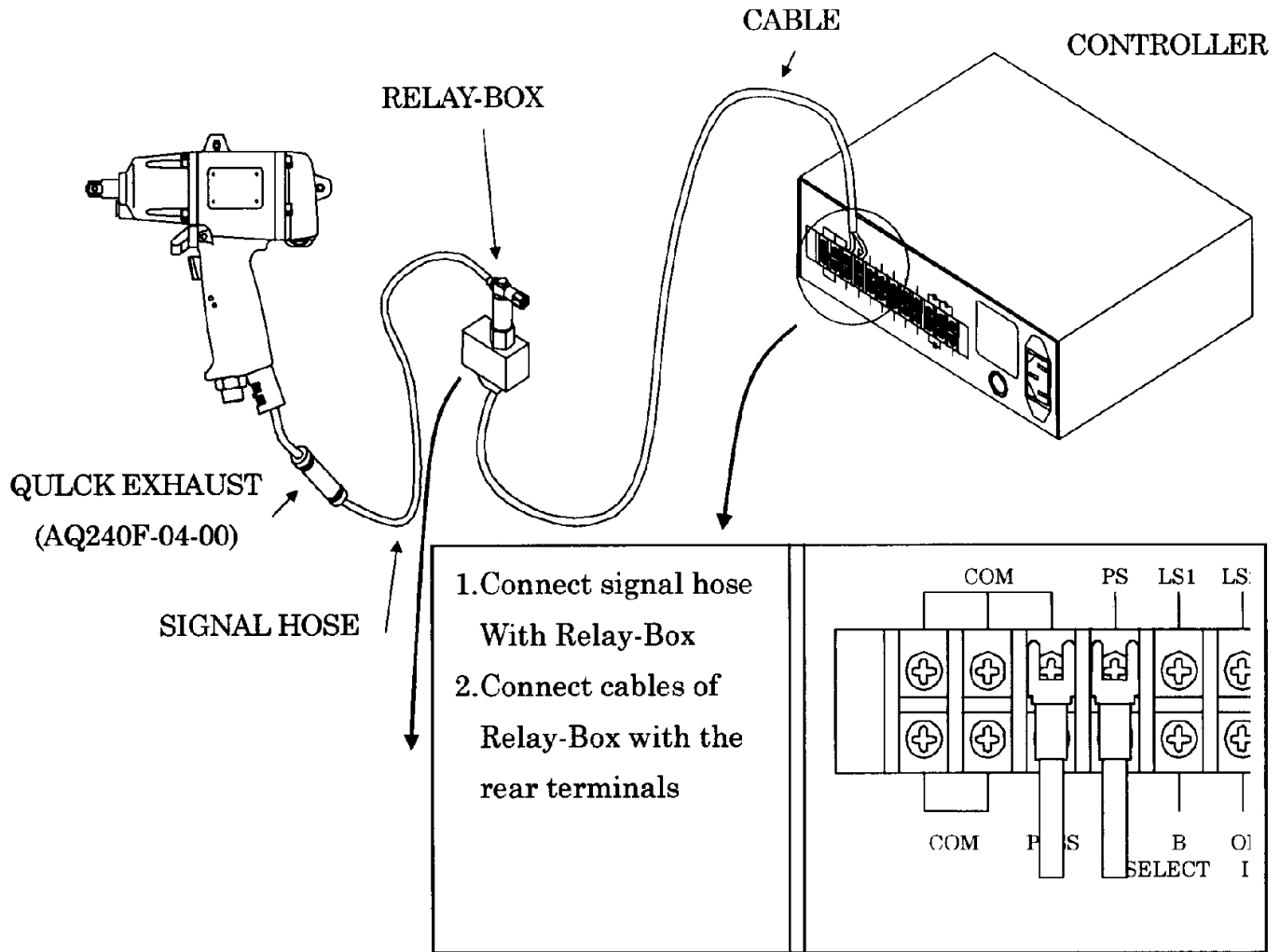

3. Signal hose fitting with Relay-Box and Quick Exhaust should be made firmly. Make pull-out test after fitting.
4. Adjust Adjuster of escape valve. Tighten Adjuster to the end. Turn Adjuster anti-clockwise 1 or 2 turns.
5. Turn on UTM-1100 and make free running of the tool.
6. Adjust Adjuster until Relay-Box does not output OK signal under free running.
7. Press PROGRAM KEY. Then press DISPLAY SELECT KEY and lamps come on in order of COUNT, VALVE TIMER ON, VALVE TIMER OFF and TIMER.
8. Press Down Key ▽ until the DIGITAL DISPLAY displays 00 both for VALVE TIMER ON and VALVE TIMER OFF.
9. Press RESET KEY or PROGRAM KEY to input above programming and small lamp of PROGRAM KEY will go off.

PROGRAMMING ON DISPLAY SELECT: Count, Valve Timer On, Valve Timer Off and Timer Functions for Option (B) and Option (C)

	Under Programming	Under Operation
COUNT	Program number of fastener	Displays remaining numbers
ON timer	Program pulsing or impacting time from bolt/nut seating. Program 0.1 ~ 9.9 seconds	Displays real remaining time from bolt/nut seating
OFF timer	Solenoid valve is automatically closed after ON timer is up. Program valve closing time which allows next fastener becomes ready	Displays real remaining time of valve closed duration
TIMER	Program monitor time of MODE 3 Program is 1 ~ 99 seconds	Displays real remaining time until timer from 1 st OK signal
T1	Program timer 1 to detect initial trouble NG Program 0.1 ~ 9.9 sections	Displays real remaining time until timer 1 is up
T2	Program timer 2 to detect cycle error NG Program 0.1 ~ 9.9 seconds	Displays real remaining time until timer 2 is up

Note: L.1 and L.2 are displayed on digital display for **T1** and **T2** for a second. Then UTM-1100(RA) becomes ready to accept timer programming for initial trouble **T1** timer and cycle error **T2** timer. Program 00 for **T1** and **T2** and these timers will be invalidated.

Lay-Out Picture

OPTION (B) UTM-1100(RA) UX-T(TM), UXR-T(TM) & ALPHA-T(TM) WITH built-in shut-off device	OPTION (C) UTM-1100(RA) U-(TM), UX-(TM) & UXR-(TM) ALPHA-(TM) & UW-(TM) WITHOUT built-in shut-off device
--	---

For both (B) and (C), connect signal hose to pressure sensor.

Only for (B), input 00 against valve timer **ON** and valve timer **OFF**. Press PROGRAM KEY. Then press DISPLAY SELECT KEY and lamps come on in order of COUNT, VALVE TIMER ON, VALVE TIMER OFF and TIMER. Press DOWN KEY ▽ until the DIGITAL DISPLAY displays 00 both for VALVE ON TIMER and VALVE OFF TIMER. Press either PROGRAM KEY or RESET KEY.

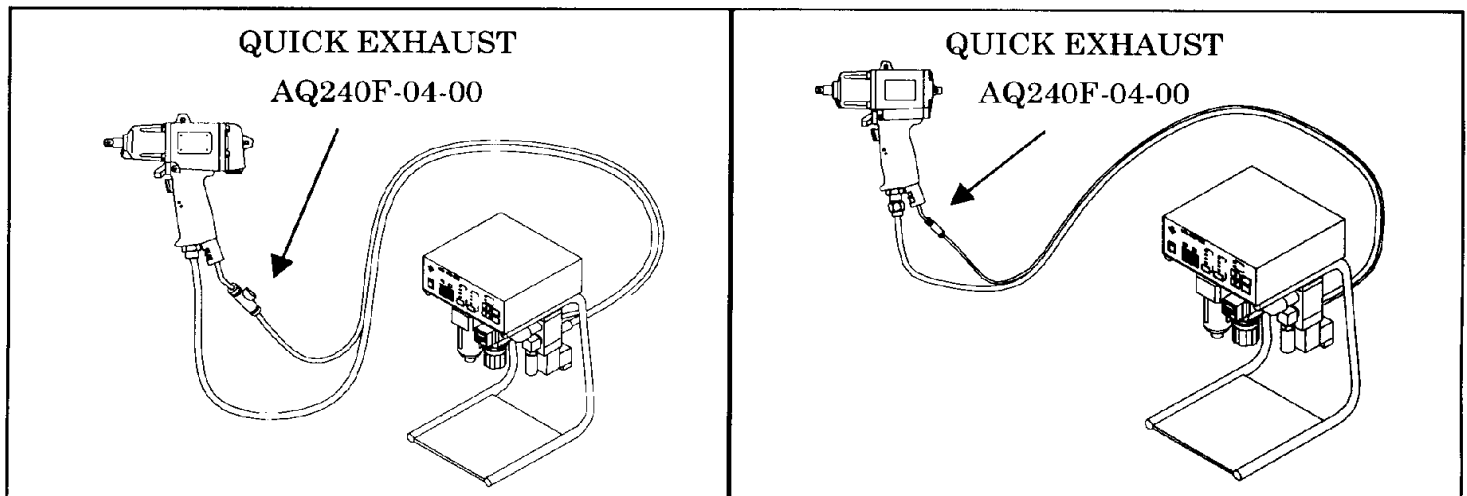

PRESSURE SENSOR SETTING FOR OPTIONS (B) AND (C)

PRESSURE SENSOR has program mode and monitor mode. This is used under monitor mode for actual operation. Change the pressure sensor to program mode and make setting.

1. Press UP KEY Δ by a finger and MODE CHANGE SWITCH \bigcirc by a pin at the same time for about a second and program mode will begin. Digital panel will display Pd3.
2. Press UP KEY Δ by a finger and one of three digital letters on digital panel will be blinking. Three digital letters are as follows. Left is Unit of Pressure **P** for PA pascal or **J** for kgf/cm². Center is for Output Operation **d** for 2-output mode, **C** for window comparator or **A** for automatic sensitivity mode setting. Right is Hysteresis of digit output, **3** for approximately 3% at full scale or **0** for approximately 0% at full scale. Press UP KEY Δ to have one of them you are going to program.
3. After having one of them press DOWN KEY ∇ and figures/signs will appear as follows:

Left:	P or J	... Set	J	For kgf/cm ²	Unit of pressure
Center:	d , C or A	... Set	d	For 2-output mode	Output operation
Right:	3 or 0	... Set	0	For 0% at full scale	Hysteresis of digital output

4. Press MODE CHANGE SWITCH and above program will be completed.
5. Program P-1 (low pressure) and P-2 (high pressure). Press MODE CHANGE SWITCH \bigcirc by a pin and DIGITAL DISPLAY will blink. Change the figures by pressing UP KEY Δ or DOWN KEY ∇ until necessary number appears on DIGITAL DISPLAY. This is P-1 setting.
6. Press again MODE CHANGE SWITCH \bigcirc by a pin and P-1 and P-2 setting will be completed.
7. Press MODE CHANGE SWITCH \bigcirc by a pin and P-1 and P-2 setting will be completed.

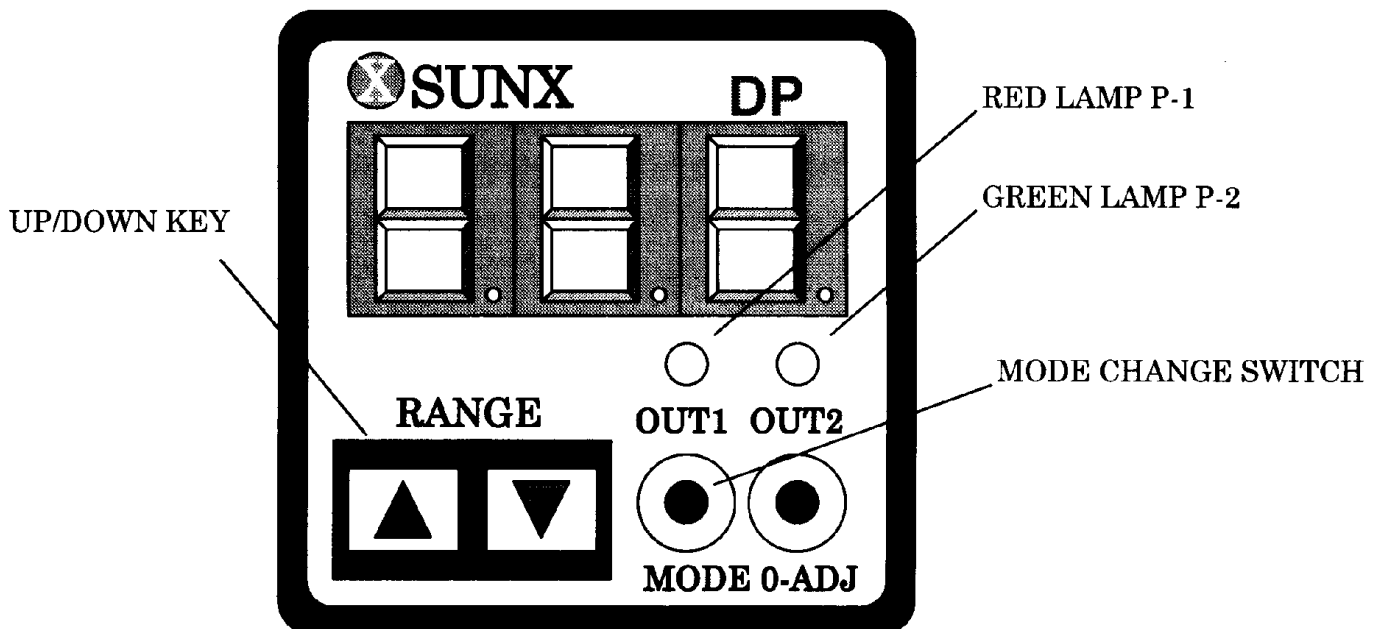

PRESSURE SENSOR SETTING FOR OPTIONS (B) AND (C)

For these 2 options, UTM-1100(RA) has **INITIAL TROUBLE DETECTION** and **CYCLE ERROR DETECTION** functions in addition to **POKAYOKE**. In order to get these functions started, UTM-1100(RA) has an air pressure sensor being capable of detecting 2 different pressure levels.

OPTION (B): This is used with UX-T(TM), UXR-T(TM) or ALPHA-T(TM) tools. The suffix (TM) means availability of signal hose connection with the tools' rear automatic shut-off valve section and the pressure sensor. Air pressure at the shut-off valve section gets high at the time of tool's lever on, gets the highest at the shut-off moment and resumes the initial atmospheric pressure. Tools are connected to pressure sensor that monitors dynamic air pressure at the shut-off section. Make pressure setting of the pressure sensor, P-1 to detect time of tool's lever on and P-2 to detect time of tool's shut off. Set $P-1 < P-2$ always.

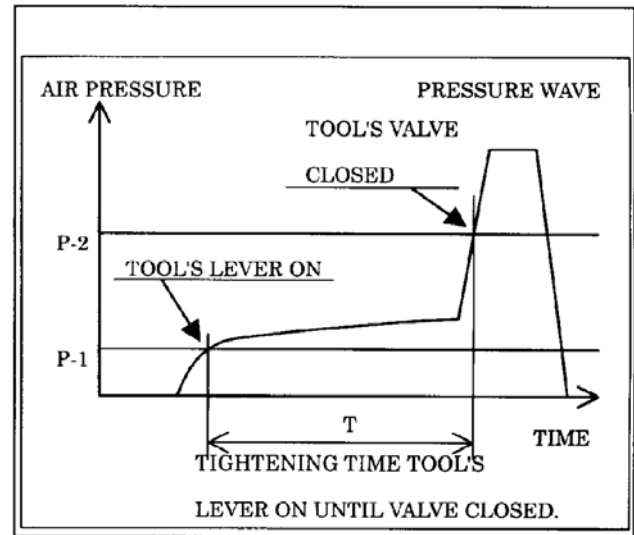

1. Make sure if **OO** is programmed against valve timer **ON** and valve timer **OFF**.
2. Time **T** is total time between tool's lever on and valve closing. If time from tool's lever on to valve closing is too short, it is considered **INITIAL TROUBLE** (torque spike due to cross-thread or double fitting). The time span depends upon your nature of joint or the condition. Program **T1** timer 0.01 ~ 0.99 seconds. On digital panel the time is expressed in 2 figures such as 99 for 0.99 seconds.
3. If time from tool's lever on to valve closing is too long or the air pressure does not exceed P-2 level, it is considered **CYCLE ERROR** (stripped thread or broken fastener). Time longer than normal tightening time will be fine. Program **T2** timer 0.1 ~ 9.9 seconds. On digital panel the time is expressed in 2 figures such as 99 for 9.9 seconds.
4. P-1 and P-2 setting
 - 4-1 P-1 should be lower than free running. Red lamp P-1 on pressure sensor comes on when the air pressure reaches P-1 level. Program P-1 so that red lamp may come on as soon as tool has been triggered.
 - 4-2 P-2 should be lower than shut off moment but should be higher than pulsing. Green lamp P-2 on pressure sensor comes on when the air pressure reaches P-2. Program P-2 so that the green lamp comes on as soon as tool's valve is closed.

OPTION (C): This is used with U-(TM), UX-(TM), UXR-(TM), ALPHA-(TM) or UW-(TM), tools. These tools do not have built-in type shut-off valve. The suffix (TM) means availability of signal hose connection with tool's small chamber just before its air motor and the pressure sensor. Air pressure at the chamber gets high at the time of tool's level on and gets the highest at the time of tool's pulsing/impacting. These tools do not have built-in type shut valve, therefore, UTM-1100(RA) compulsorily stops air supply to the tool by means of solenoid valve after pulsing/impacting. Air pressure at the chamber resumes the initial atmospheric pressure at the time of solenoid valve closing. Make pressure setting to detect time of tool's lever on and of tool's bolt seating. Set P-1 < P-2 always.

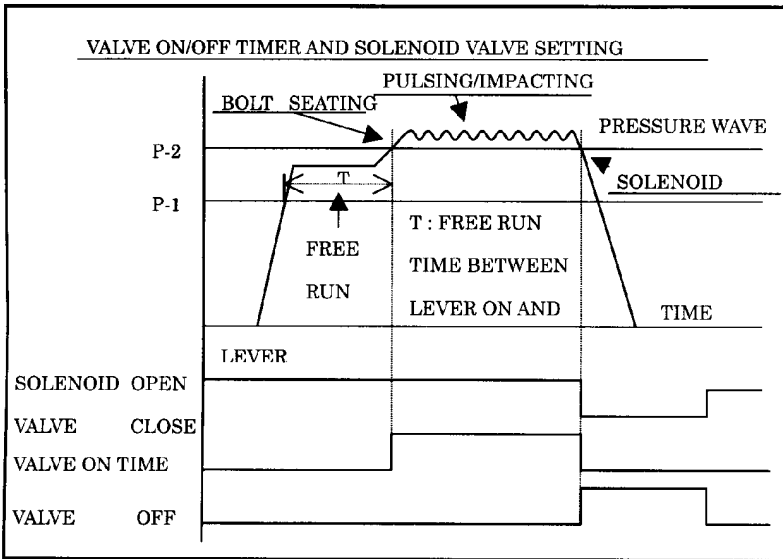

1. Time **T** is total time between tool's lever on and bolt seating. If time from tool's lever on to bolt seating is too short, it is considered **INITIAL TROUBLE** (torque spike due to cross thread or double fitting). The time span depends upon your nature of joint or the condition. Program **T1** timer 0.01 ~ 0.99 seconds. On digital panel the time is expressed in 2 figures such as 99 for 0.99 seconds.

2. If time from tool's lever on to bolt seating is too long or the air pressure does not exceed P-2 level, it is considered **CYCLE ERROR** (stripped thread or broken fastener). Time longer than normal free running time will be fine. Program **T2** timer 0.1 ~ 9.9 seconds. On digital panel the time is expressed in 2 figures such as 99 for 9.9 seconds.

3. For **OPTION (C)**, valve timers **ON/OFF** is closely correlated to P-1/P-2 programming for pressure sensor. Make P-1 and P-2 setting first. Monitor pressure under free running and pulsing/impacting on digital display of pressure sensor.

- 3-1 P-1 should be lower than free running. Red lamp P-1 on pressure sensor comes when the air pressure reaches P-1 level. Program P-1 so that the red lamp may come on as soon as the tool has been triggered.
- 3-2 P-2 should be between free running and pulse/impacting. Program P-2 so that green lamp comes on as soon as pulsing/impacting starts. If pressure difference between free running and pulsing/impacting is not much, program same pressure under pulsing/impacting for P-2.
- 4. Determine and program valve timers **ON/OFF** by referring to page 8 and as per your applications.

FUNCTIONING POINT OF POKOYOKE AND THE NG REPAIRING

All combinations (A), (B) and (C) can be used in the following three ways. Open four screws to remove the box cover and set DIP switches.

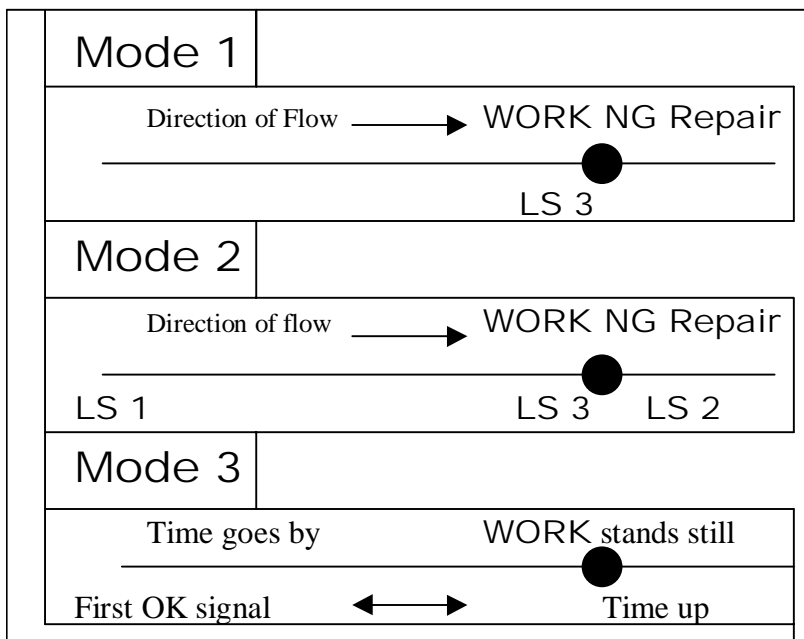
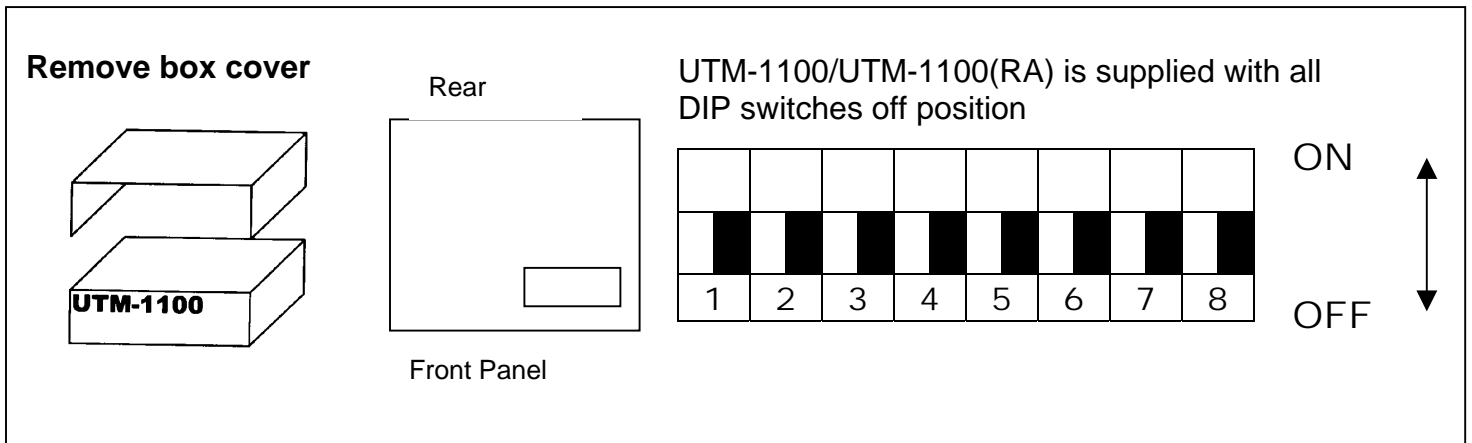

1. Set the DIP switch all off position.
2. Connect LS3 with COM and LS3 terminals of UTM-1100.

1. Switch on DIP 1 only.
2. Connect LS1, LS2 and LS3 with COM, LS1 and LS3 terminals of UTM-1100.

1. Switch on DIP 2 only.
2. Program time of **TIMER**. See page 8 how to program.
3. Up to 99 seconds programmable.

LS3 for Mode 1 and 2.... Tighten

programmed number of fasteners before the WORK switches on **LS3**. If all fasteners are not tightened before **LS3**, UTM-1100 provides NG judgement with NG lamp on, buzzer sounding and digital panel displaying remaining numbers.

LS1 for Mode 2.... Switching **LS1** by the work will reset last OK/NG with start lamp on and allow POKAYOKE to being. UTM-1100 displays programmed number of fasteners.

LS2 for Mode 2.... If NG is provided at **LS3**, tighten remaining fasteners before the work switches on **LS2** and UTM-1100 will provide GOOD judgement on the front panel. Section **LS3** and **LS2** is for NG repairing.

Timer for Mode 3.... First OK signal gets this function started and time goes by. Time of **TIMER** is up and then UTM-1100 detects whether programmed number of fasteners have been tightened.

OTHER FUNCTIONS OF DIP SWITCHES

- 3 Switch on to maintain OK signal until **LS3** point.
- 5 Switch on to activate solenoid/pressure sensor check. See OFF TIMER NG page 14.
- 7 Switch on to allow automatic overriding initial trouble or cycle error NG. You can open the NG fastener and restart the operation without manual reset on the front panel.

OK INDICATION, EXTRA SWITCH, NG REPAIR & WORK SELECT

OK Indication for Mode 1 and 2

1. Display of Digital panel becomes zero and UTM-1100 provides judgement for GOOD with OK lamp ON before work switches on **LS3**. This OK indication is maintained until work switches on **LS3**.
2. OK lamp goes off and UTM-1100 is reset when work switches on **LS3**. UTM-1100 displays programmed number of fasteners on Digital panel.

OK indication for Mode 3

1. When programmed number of fasteners are tightened before time of **TIMER** is up, UTM-1100 provides judgement for GOOD with OK lamp ON. This OK indication is maintained for 2.0 seconds and goes off later. And then UTM-1100 is reset and displays programmed number of fasteners again.

Extra Switches

PASS Set an external switch near by the operator for connection with COM and PASS of UTM-1100. Press the switch to have work with no fasteners passed.

RESET Set another switch near by the operator for connection with COM and reset of UTM-1100. Press this switch to cancel NG indication or reset UTM-1100.

QL Open page 4 and you will see **Option (A)** showing both fastening tool and hand torque wrench. This hand torque wrench has a built-in micro switch connected with COM and QL of UTM-1100. UTM-1100 counts down OK signal from micro switch built-in type hand torque wrench, will help NG repairing.

NG indication and repairing

1. UTM-1100 provides judgement for NG with NG lamp ON, buzzer sounding and Digital Panel displaying remaining numbers

2. Repair NG as follows

① Tighten remaining fasteners by the tool

② Tighten remaining fasteners by **QL**

③ Switch on **PASS** terminal

④ Press **RESET** key of UTM-1100

⑤ Switch on reset terminal in the rear

} → **Providing OK, UTM-1100 is reset**

} → **UTM-1100 is reset without OK indication**

Work Select

If plural works are in an assembly line, use this function and UTM-1100 will discriminate up to 4 types. Connect 2 limit switches with COM, A and B terminals of UTM-1100. The number is automatically changed when the work is at the entrance under ※ conditions.

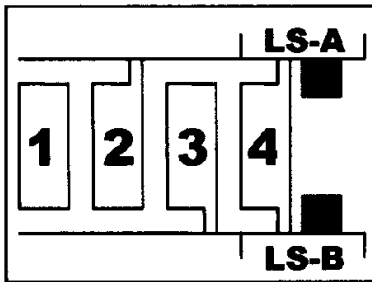

- ※ UTM-1100 is reset or OK lamp goes off (mode 1, 2 & 3)
- ※ Last work switches on LS3 at the exit with OK result (mode 1 & 2)
- ※ **TIMER** is up with OK result (mode 3)

NO.	A	B
1	OFF	OFF
2	ON	OFF
3	OFF	ON
4	ON	ON

ERROR DISPLAY AND BATTERY CHANGE

1. Error Display and Battery Change

Turn on the power switch and UTM-1100 will begin a self-diagnostic check with buzzer sounding and digital display **CH**. If something is wrong with the unit, an Error Code will display and the controller must be serviced.

Error	Display	Explanation	Counter Measures
ROM	E 1	ROM is out of order or abnormally functioning.	1. Press RESET KEY to get the self-diagnostic function started again.
RAM	E 2	RAM is out order or abnormally functioning.	1. Press RESET KEY to get the self-diagnostic function started again. 2. RAM must be replaced.
BATTERY	b E	Back-up battery is discharged or defective	1. Reset and try again. 2. If the trial does not work, replace battery.
OFF TIMER NG	O F	OK signal is not switched off due to troubles with either Solenoid Valve or Pressure Sensor.	This error is detected only when DIP SWITCH 5 is ON position. See Page 13. Check Solenoid Valve and Pressure Sensor. Either one must be replaced.
INITIAL TROUBLE	L E	Initial trouble was detected due to double fitting or cross thread.	1. Open NG fastener and try again 2. Input NG reset signal.
CYCLE ERROR	C E	Air pressure was below P-2 when T 2 timer was up. Fastener was not tightened.	1. Check the thread of fastener 2. Input NG reset signal

2. Battery Change

Open box cover and replace battery.

