



**REPAIR MANUAL**

# **URW SERIES**

**URW-6, 8, 9, 10 & 12 Series  
Repair Manual**



---

# Contents

---

	<b><u>Page Number</u></b>
1. <b>Tools Needed for Repair</b>	1
2. <b>Disassembly and Reassembly of the Cam Casing</b>	2-4
3. <b>Disassembly and Reassembly of the Gear Section</b>	5-9
4. <b>Disassembly and Reassembly of the Air Motor Section</b>	10-14
5. <b>Recommended Maintenance</b>	15

---

## Tools Needed for Repair

---

1. One Set of T-Handle Metric Allen Wrenches
2. Flat-Bladed Screwdrivers
3. Brass Hammer
4. Dead Blow Hammer
5. 10 oz. Ball Peen Hammer
6. One Set of Pin Punches
7. One Set of O-Ring Picks
8. 6" Adjustable End Wrench
9. 12" Adjustable End Wrench
10. Medium Pair Channel Locks or Adjustable Jaw Pliers
11. Medium Honing Stone
12. 220 Grit Wet/Dry Sandpaper
13. Lap Plate
14. Loc-Tite #242
15. CFC Free Degreaser-Cleanser
16. Loc-Tite Accelerator
17. Arbor Press
18. UTA-204 and UMS Transducers and UFT Joint Simulators
19. Needle Nose Pliers
20. Propane Torch

---

# Disassembly and Reassembly of the Cam Casing

---

## **Disassembly**

1. Remove the Rod Guide Bolts and Rod Guide Nuts.
2. Remove the Rod Guides, Ratchet, Checker, Springs, and Rod Plate Spring.
3. Remove the Cam Casing from the tool (left-hand thread).
  - On the URW-6, you must loosen the Gear Casing Lock Nut first and then remove the Connector, Cam, Bearing, Spacer, Thrust Washers, and Thrust Bearing.
  - On the URW-8N & 9N, over-tightening the Handle Nut will keep the Casing from turning.
4. Remove the Operating Rod, Cam Roller, Cam Roller Pin, Cam Roller Push Pin(s), and Spring(s).
5. Thoroughly clean all parts.

## **Inspection of Parts for Wear**

1. **Rod Guides:** The Ratchet should turn freely in the Rod Guides but should not move from side to side; replace as needed.
2. **Ratchet and Checker:** The teeth should come to a point; replace if they are rounded off. The flats inside of the Ratchet should not be pitted or grooved; replace as needed.
3. **Operating Rod:** The end of the Rod that contacts the Ratchet should come to a point; replace if it's rounded.
4. **Cam Roller and Cam Roller Pin:** The Cam Roller should be round and smooth; replace if it has flat spots and pitting. The Cam Roller Pin should be inspected for shininess and grooving; replace as needed.
5. **Rod Plate Spring:** Inspect the Rod Plate Spring for cracks and wear from the Operating Rod; replace as needed.
6. **Springs:** Check for the correct dimension of the Spring; replace as needed.

## **Reassembly**

1. Install the Cam Roller Push Pin(s) and Spring(s) into the Cam Casing. Put a light coat of grease on both parts.
2. Install the Cam Roller and the Cam Roller Pin into the Operating Rod. Now install the Operating Rod into the Cam Casing making sure that the Cam Roller Push Pin gets under the Cam Roller Pin. Put a light coat of grease on all parts.
3. Put a light coat of grease on the Operating Rod and install the Rod Plate Spring.
4. Install the Springs and Checker onto the Cam Casing.
5. Install the Ratchet and Rod Guides being sure to line up the slot in the Rod Guide with the notch on the Checker. Install the Rod Guide Bolts and Nuts and tighten.
6. When installing the Cam Casing Assembly back onto the Gear Casing, the Cam Casing Assembly will have to be shimmed to adjust the Operating Rod to the Ratchet.

---

## Disassembly and Reassembly of the Cam Casing (cont.)

---

### **Adjusting the Cam Casing Assembly**

#### **For all Tools Except the URW-6:**

1. While running the tool, reinstall the Cam Casing to the Gear Casing.
2. Watch the Ratchet as the Cam Casing turns down onto the Gear Casing. When the Ratchet starts to turn, mark its position and continue to allow the Cam Casing to turn down onto the Gear Casing until the Ratchet stops or the Cam Casing bottoms out.
3. Turn the Cam Casing back halfway between the two points and measure the amount of Adjusting Spacers it will take to take up the space between the Cam Casing and the Gear Casing.

#### **For the URW-6 Only:**

1. Install the Connector into the Gear Casing. Now install the Thrust Washers, Thrust Bearing, Spacer, Bearing, and Cam into the Connector.
2. While running the tool, reinstall the Cam Casing onto the Connector.
3. Watch the Ratchet as the Cam Casing turns down onto the Connector. When the Ratchet starts to turn, mark its position and continue to allow the Cam Casing to turn onto the Connector until the Ratchet stops or the Cam Casing bottoms out.
4. Turn the Cam Casing back halfway between the two points and measure the distance from the bottom of the Cam Casing to the top of the Gear Casing.
5. Turn the Cam Casing down until it bottoms out and measure the distance from the bottom of the Cam Casing to the top of the Gear Casing. Subtract the two measurements; this is the amount of Adjusting Spacers that should be put between the Cam Casing and the Connector.

# Disassembly and Reassembly of the Cam Casing

## URW - Cam Casing

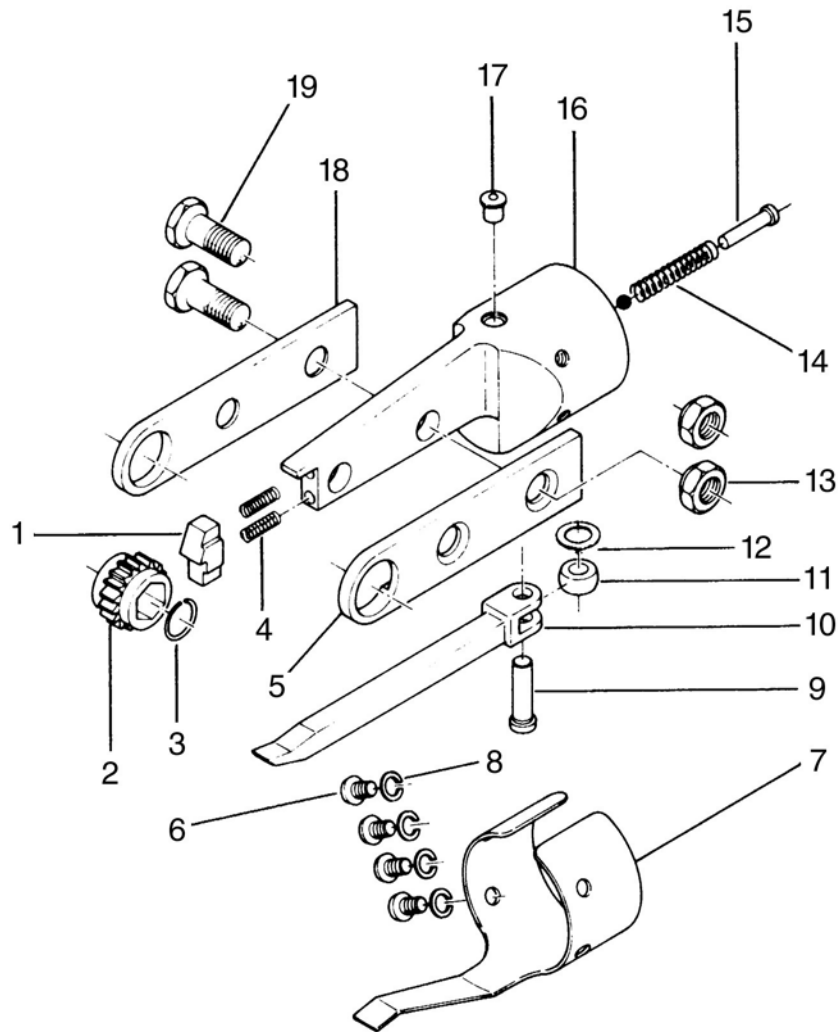

Part Number	Description	Part Number	Description
1	Checker	11	Cam Roller
2	Ratchet	12	Spacer (URW-8N Only)
3	Snap Ring	13	Rod Guide Nut
4	Spring	14	Spring
5	Rod Guide Left	15	Cam Roller Push Pin
6	Round Head Screw	16	Cam Casing
7	Rod Plate Spring	17	Grease Cup
8	Spring Washer	18	Rod Guide Right
9	Cam Roller Pin	19	Rod Guide Bolt
10	Operating Rod		

---

# Disassembly and Reassembly of the Gear Casing

---

## **Disassembly**

1. Remove the Cam Casing (left-hand thread).
2. **On the URW-6 Only:**
  - a. Remove the Connector from the Cam Casing. Remove the Cam, Bearing, Spacer, Thrust Washers, and Thrust Bearing.
  - b. Remove the Gear Casing, Gear Cage, Roller Pins, Planet Gears, Needle Roller Bearings, and Bearing.
  - c. Remove the Allen Head Dog Point Screw from the side of the Gear Casing. Remove the Internal Gear and Bearing.
3. **On the URW-8N & 9N:**
  - a. Using a Bearing Separator, put it between the Cam and the Casing to remove the Cam, Key, Bearing, Thrust Rear Spacer or Spacer, and Thrust Bearing from the Casing.
  - b. Remove the Casing from the Handle.
  - c. Remove the Air Motor from the Casing.
  - d. Remove the Bearing, Gear Cage, Needle Rollers, Planet Gear Bushings (on URW-8N only), and Internal Gear from the Casing.
4. **On the URW-8:**
  - a. Using a Bearing Separator, put it between the Cam and the Casing to remove the Cam, Key, Bearing, Thrust Rear Washer, and Thrust Bearing from the Casing.
  - b. Remove the Gear Casing from the Handle.
  - c. Remove the Gear Cage, Roller Pins, Planet Gear Bushings, and Planet Gears from the Gear Casing.
  - d. Remove the Internal Gear from the Gear Casing.
5. **On the URW-10N, 12N, 12NA & 12NB:**
  - a. Remove the Cam, Bearing, and Spacer from the Gear Casing.
  - b. Remove the Gear Casing from the Casing. **Note:** Over-tightening the Handle Nut will help keep the casing from turning.
  - c. Remove the Gear Cage, Planet Gear Pins, Needle Roller Bearing, Bearing, and Planet Gears from the Gear Casing.
6. Thoroughly clean all parts and blow dry.

## **Inspection of Parts for Wear**

1. **Cam:** Inspect for pitting and flat spots; replace as needed.
2. **Needle Rollers and Planet Gear Pins:** Inspect for shininess and grooving; replace as needed.
3. **Planet Gears and Internal Gears:** Inspect teeth for pitting and grooving; replace as needed.
4. **Bearings:** Inspect for side play and knocking; replace as needed.

---

## Disassembly and Reassembly of the Gear Casing (cont.)

---

### **Reassembly**

1. Grease all Bearings, Gears, and Internal Gears.
2. **For the URW-6 Only:**
  - a. Install the Bearing, Internal Gear, and Allen Head Dog Point Screw into the Gear Casing.
  - b. Install the Needle Roller Bearing into the Planet Gears and both Planet Gears into the Gear Cage. Put the Roller Pins into the Gear Cage and through the Planet Gears.
  - c. Install the Spacer onto the Gear Cage and install the Gear Cage into the Gear Casing. Install the Bearing into the Gear Cage.
  - d. Install the Gear Casing onto the Air Motor Casing.
  - e. Install the Connector onto the Gear Casing and install the Thrust Washers, Thrust Bearing, Spacer, Bearing, and Cam into the Connector.
3. **For the URW-8N & 9N:**
  - a. Install the Internal Gear into the Casing.
  - b. Install the Planet Gear Bushing (URW-8N only) into the Planet Gear and install them into the Gear Cage. Install the Needle Rollers into the Gear Cage.
  - c. Install the Gear Cage into the Casing and install the Key into the Gear Cage.
  - d. Install the Bearing, Thrust Rear Spacer or Spacer, and Thrust Bearing onto the Cam. Press the Cam onto the Gear Cage making sure to line up the Key in the Gear Cage with the key way in the Cam. **Note:** The Gear Cage should extend out past the Cam about 2mm.
4. **For the URW-8:**
  - a. Install the Internal Gear into the Gear Casing.
  - b. Install the Planet Gear Bushing into the Planet Gears and install the Planet Gears into the Gear Cage. Install the Needle Rollers into the Gear Cage.
  - c. Install the Gear Cage into the Gear Casing and install the Key into the Gear Cage.
  - d. Install the Bearing, Thrust Rear Spacer or Spacer, and Thrust Bearing onto the Cam. Press the Cam onto the Gear Cage making sure to line up the Key in the Gear Cage with the key way in the Cam. **Note:** The Gear Cage should extend out past the Cam about 2mm.
5. **For the URW-10N, 12N, 12NA, & 12NB:**
  - a. Install the Needle Roller Bearing into the Planet Gears and both Planet Gears into the Gear Cage. Put the Planet Gear Pins into the Gear Cage and through the Planet Gears.
  - b. Install the Spacer onto the Gear Cage and install the Gear Cage into the Gear Casing. Install the Bearing onto the Gear Cage.
  - c. Install the Bearing and Cam onto the Gear Cage.

# Disassembly and Reassembly of the Gear Casing (cont.)

## URW-6 - Gear Casing

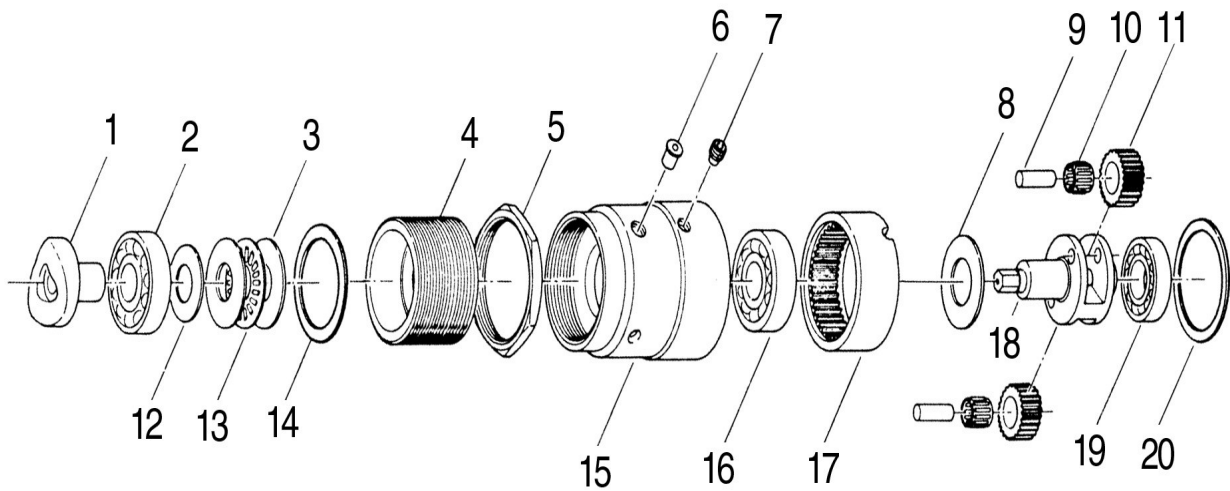

Part Number	Description	Part Number	Description
1	Cam	11	Planet Gear
2	Bearing	12	Spacer
3	Thrust Washer	13	Thrust Bearing
4	Connector	14	Adjusting Spacer
5	Cam Casing Lock Nut	15	Gear Casing
6	Grease Cup	16	Bearing
7	Set Screw	17	Internal Gear
8	Spacer	18	Gear Cage
9	Roller Pin	19	Bearing
10	Needle Roller Pin	20	Spacer

## Disassembly and Reassembly of the Gear Casing (cont.)

### URW - Gear Casing

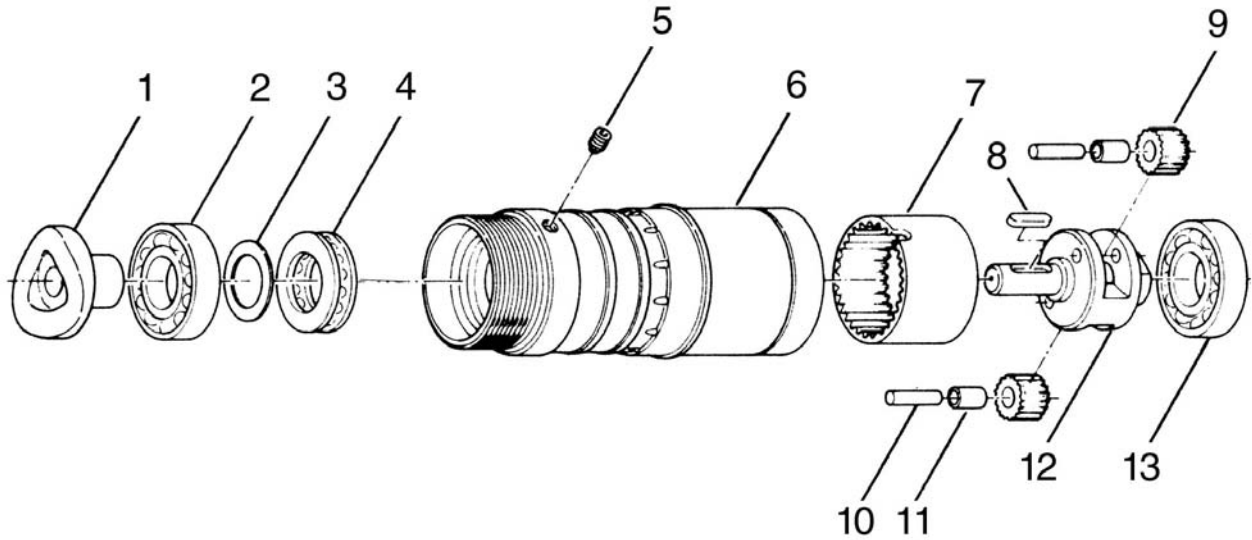

Part Number	Description	Part Number	Description
1	Cam	8	Key
2	Bearing	9	Planet Gear
3	Spacer	10	Roller Pin
4	Thrust Bearing	11	Bushing
5	Set Screw	12	Gear Cage
6	Gear Casing	13	Bearing
7	Internal Gear		

---

# Disassembly and Reassembly of the Air Motor

---

## **Disassembly**

### 1. For the **URW-6:**

- a. Remove the Gear Casing from the Handle Casing.
- b. Remove the Air Motor from the Handle Casing. **Note:** Applying heat to the Handle may help in removing the Air Motor.
- c. Tap on the splined end of the Rotor with a brass hammer while holding the Air Motor firmly in your hand. Remove the Front Plate, Bearing, and Cylinder.
- d. Press the Rotor out of the Rear Plate and Bearing.

### 2. For the **URW-8N & 9N:**

- a. Remove the Casing from the Handle Casing.
- b. Remove the Air Motor from the Casing.
- c. Tap on the splined end of the Rotor with a brass hammer while holding the Air Motor firmly in your hand. Remove the Front Plate, Bearing, and Cylinder.
- d. Remove the Snap Ring, Rear Plate Spacer, and O-ring from the Rear Plate. Press the Rotor out of the Rear Plate and the Bearing out of the Rear Plate.

### 3. For the **URW-8:**

- a. Remove the Gear Casing from the Handle Casing.
- b. Remove the Air Motor from the Handle Casing. **Note:** Applying heat to the Handle Casing may help in removing the Air Motor.
- c. Tap on the splined end of the Rotor with a brass hammer while holding the Air Motor firmly in your hand. Remove the Front Plate, Bearing, and Cylinder.
- d. Remove the Snap Ring, Rear Plate Spacer, and O-Ring from the Rear Plate. Press the Rotor out of the Rear Plate and the Bearing out of the Rear Plate.

### 4. For the **URW-10N, 12N, 12NA & 12NB:**

- a. Remove the Casing from the Handle Casing.
- b. Remove the Air Motor from the Casing.
- c. Tap on the splined end of the Rotor with a brass hammer while holding the Air Motor firmly in your hand. Remove the Front Plate, Bearing and Cylinder.
- d. Press the Rotor out of the Rear Plate and Bearing.

### 5. Thoroughly clean all parts and blow dry.

## **Inspection of Parts for Wear**

1. **Air Motor Blades:** Inspect Blades for splitting and side wear; replace if worn.
2. **Bearings:** Inspect Bearings for side play and knocking; replace if worn.
3. **Cylinder:** Inspect Cylinder for waviness; replace if worn.

---

## Disassembly and Reassembly of the Air Motor (cont.)

---

4. **Air Motor Plates:** Inspect Plates for grooving. Light marks can be lapped out using a figure-eight motion with 220 grit sandpaper on a Lap Plate. If heavy grooving is noted, replace.
5. **Rotor:** Inspect Rotor for sharp edges in Blade Slots and pitting and grooving on Plate Surface. Light marks can be stoned with a medium oil stone. If deep markings exist, replace.
6. **O-Ring:** Inspect the O-rings for splitting or chipping; replace if necessary.

### **Reassembly**

#### 1. **For the URW-6:**

- a. Remove the Casing from the Handle Casing.
- b. Grease all Bearings. Place the Rear Plate on the rear of the Rotor and press the Rear Bearing onto the Rotor. **Note:** There should be a slight amount of drag between the Rear Plate and the Rotor.
- c. Lightly coat the Blades with air motor oil and install them in the Rotor flat-side out.
- d. Place the Cylinder down over the Rotor making sure to line up the air port holes in the Rear Plate with the holes in the Cylinder.
- e. Install the Front Plate onto the Rotor and press the Front Bearing over the Rotor and into the Front Plate. **Note:** The Cylinder should be tight between the Front and Rear Plate and the Rotor should turn freely.
- f. Install the alignment Pin through the Rear Plate, Cylinder, and into the Front Plate.
- g. Install the Air Motor into the Handle lining up the hole in the Handle with the alignment Pin in the Air Motor.

#### 2. **For the URW-8N & 9N:**

- a. Grease all Bearings. Place the Rear Plate on the rear of the Rotor and press the Rear Bearing onto the Rotor. **Note:** There should be a slight amount of drag between the Rear Plate and the Rotor.
- b. Lightly coat the Blades with air motor oil and install them in the Rotor flat-side out.
- c. Place the Cylinder down over the Rotor making sure to line up the air port holes and Roll Pin in the Cylinder with the holes in the Rear Plate.
- d. Install the Front Plate onto the Rotor aligning the Roll Pin in the Cylinder and press the Front Bearing over the Rotor and into the Front Plate. **Note:** The Cylinder should be tight between the Front and Rear Plate and the Rotor should turn freely.
- e. Install the O-ring, Rear Plate Spacer, and Snap Ring into the Rear Plate.
- f. Install the Air Motor into the Casing and install the Handle.

#### 3. **For the URW-8:**

- a. Grease all Bearings. Place the Rear Plate on the rear of the Rotor and press the Rear Bearing onto the Rotor. **Note:** There should be a slight amount of drag between the Rear Plate and the Rotor.
- b. Lightly coat the Blades with air motor oil and install them in the Rotor flat-side out.
- c. Place the Cylinder down over the Rotor making sure to line up the air port holes and Roll Pin in the Cylinder with the holes in the Rear Plate.

---

## Disassembly and Reassembly of the Air Motor (cont.)

---

- d. Install the Front Plate onto the Rotor aligning the Roll Pin in the Cylinder and press the Front Bearing over the Rotor and into the Front Plate. **Note:** The Cylinder should be tight between the Front and Rear Plate and the Rotor should turn freely
  - e. Install the O-ring, Rear Plate Spacer and Snap Ring into the Rear Plate.
  - f. Install the Air Motor into the Handle lining up the hole in the Handle with the alignment Pin in the Air Motor.
4. **For the URW-10N, 12N, 12NA & 12NB:**
- a. Grease all Bearings. Place the Rear Plate on the rear of the Rotor and press the Rear Bearing onto the Rotor. **Note:** There should be a slight amount of drag between the Rear Plate and the Rotor.
  - b. Lightly coat the Blades with air motor oil and install them in the Rotor so that the bevel of the Blade goes with the bevel of the Rotor.
  - c. Place the Cylinder down over the Rotor making sure to line up the air port holes and Roll Pin in the Cylinder with the holes in the Rear Plate.
  - d. Install the Front Plate onto the Rotor aligning the Roll Pin in the Cylinder and press the Front Bearing over the Rotor and into the Front Plate. **Note:** The Cylinder should be tight between the Front and Rear Plate and the Rotor should turn freely.
  - e. Install the Air Motor into the Casing and install the Handle.

## Disassembly and Reassembly of the Air Motor (cont.)

### URW - Air Motor

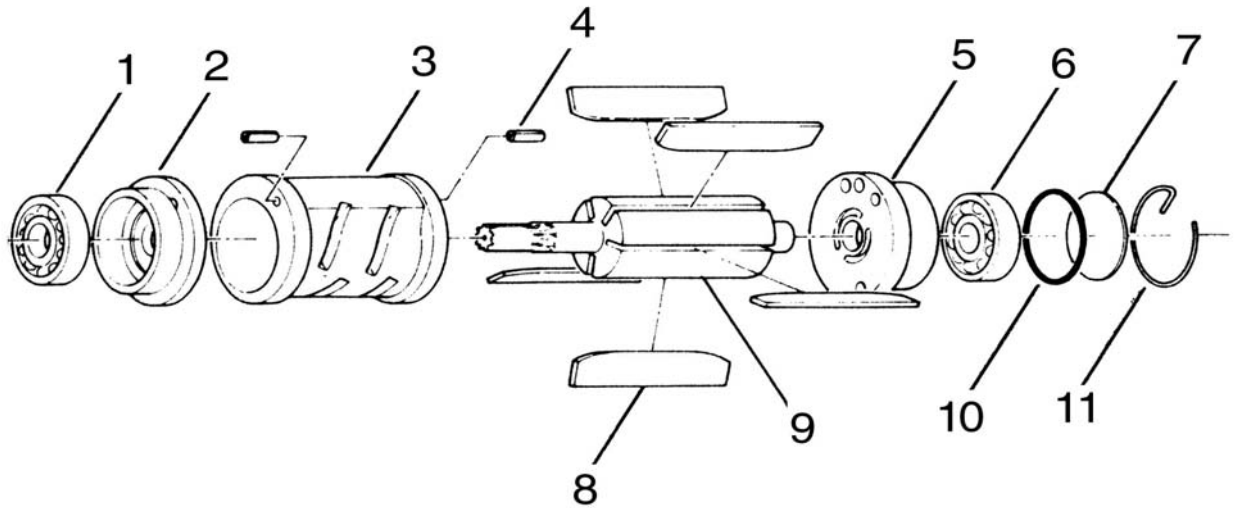

Part Number	Description	Part Number	Description
1	Bearing	7	Rear Plate Spacer (URW-8 & 9)
2	Front Plate	8	Blade
3	Cylinder	9	Rotor
4	Roll Pin	10	O-Ring (URW-8 & 9)
5	Rear Plate	11	Snap Ring (URW-8 & 9)
6	Bearing		

---

## Recommended Maintenance

---

The tools should be thoroughly cleaned and inspected every three months. Always use genuine Uryu parts.

### **Lubrication**

Use a light spindle oil for the air motor like Mobile Spindle Oil No. 1, Shell Spindle Oil 60, and/or equivalent.

Use a high-quality grease for the Gearing, Cam, and Ratcheting sections like Shell Alvania No. 2, Mobilplex 2, and/or equivalent.

