



# PT700P PRO TAPPER

## Wespro Pneumatic Tools



**DO NOT** clamp the handle in a vise or other clamping device! Also **DO NOT** stamp the aluminum handle body anywhere with letter or number stamps. In doing so, the valve box can be fractured thus requiring a new handle. If marking is required, it should be done with an engraving tool.

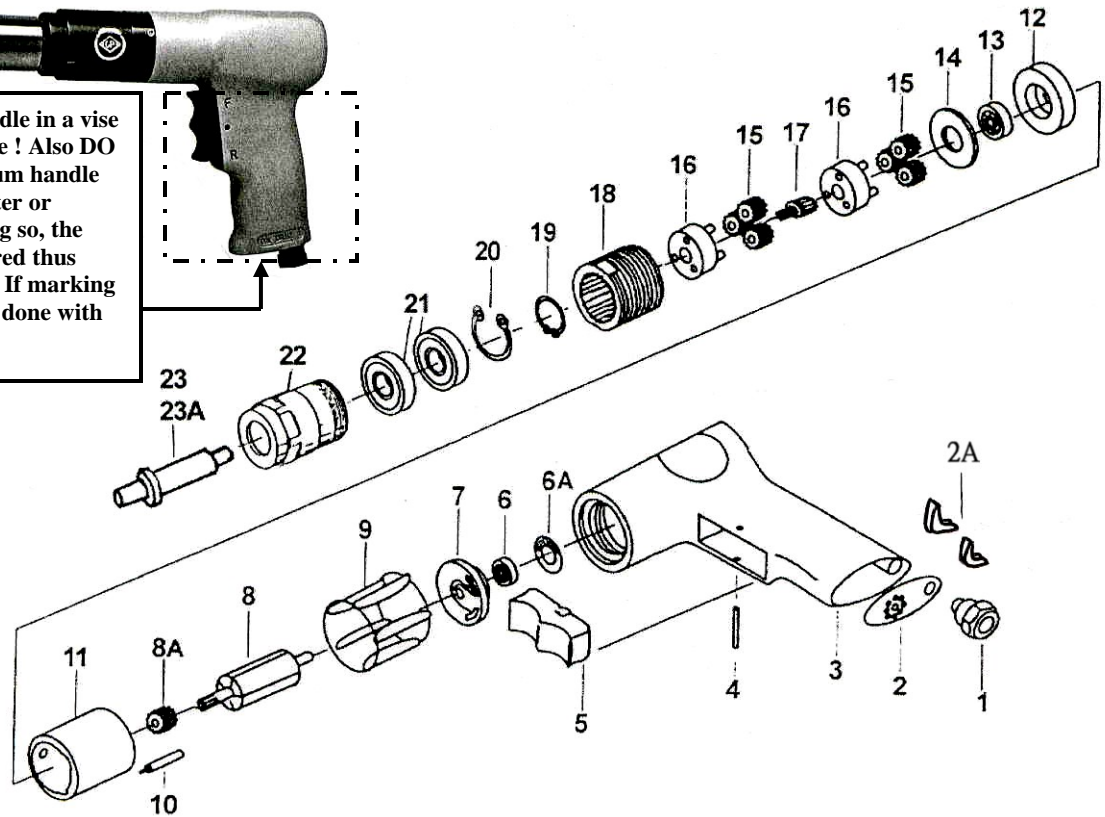

\* Handle Assembly 175389  
( Include parts #1, 2, 2A, 3, 4, 5)

<u>No.</u>	<u>Description</u>	<u>Order Code</u>	<u>Qty</u>	<u>No.</u>	<u>Description</u>	<u>Order Code</u>	<u>Qty</u>
1	Air Inlet	148378	1	12	Front End Plate	149255	1
2	Diffuser Exhaust	149200	1	13	Ball Bearing	112054	1
2A	Silencer	179555	2	14	Washer	149211	1
3	Handle	175388	1	15	Planet Gear	149256	6
4	Pin	149202	1	16	Gear Cage	149257	2
5	Trigger	149204	1	17	Sun Gear	149240	1
6A	Gasket	188190	1	18	Internal Gear	149258	1
6	Ball Bearing	112062	1	19	Retainer Ring	149223	1
7	Rear End Plate	188199	1	20	Retainer Ring	149242	1
8	Rotor	148548	1	21	Ball Bearing	112043	2
8A	Sun Gear	149250	1	22	Nose Housing	148566	1
9	Rotor Blade	148546	5	23	Drive Spindle (JT1)	148567	1
10	Roller Pin	149208	2	23A	Drive Spindle (B12)	173060	1
11	Cylinder	148551	1				