

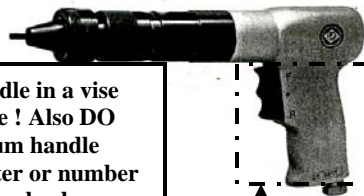

PS400C ADJUSTABLE CLUTCH PULL SETTER

Wespro Pneumatic Tools



DO NOT clamp the handle in a vise or other clamping device ! Also **DO NOT** stamp the aluminum handle body anywhere with letter or number stamps. In doing so, the valve box can be fractured thus requiring a new handle. If marking is required, it should be done with an engraving tool.

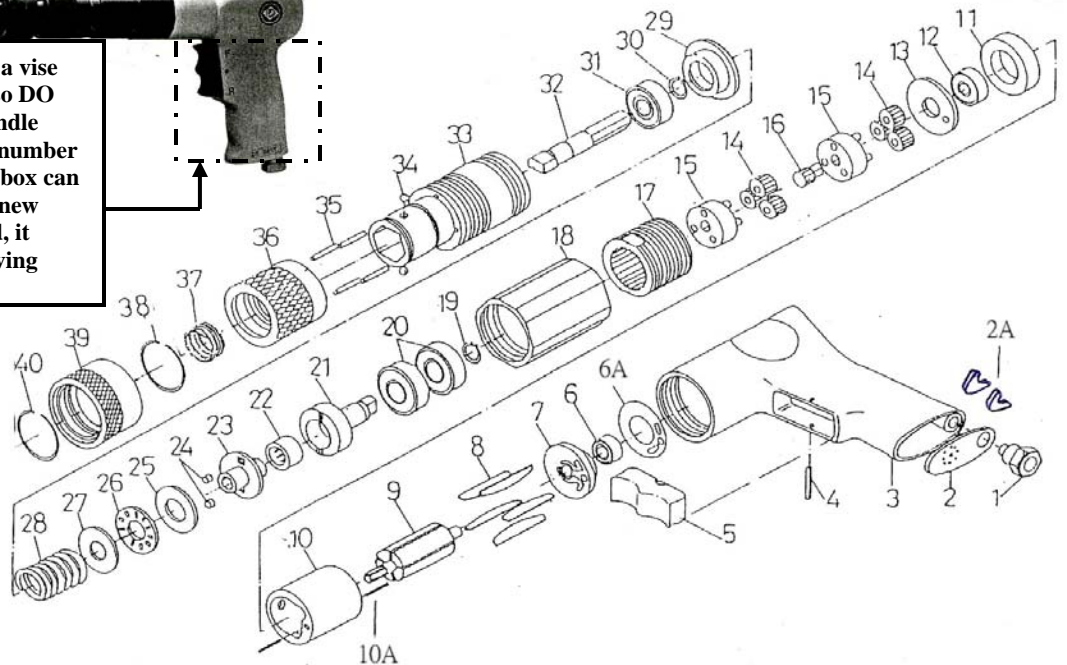

* Handle Assembly 152513
(Include parts #1,2,2A,3,4,5)

<u>No.</u>	<u>Description</u>	<u>Order Code</u>	<u>Qty</u>	<u>No.</u>	<u>Description</u>	<u>Order Code</u>	<u>Qty</u>
1	Air Inlet	148378	1	20	Ball Bearing	112041	2
2	Diffuser Exhaust	149200	1	21	Clutch	175258	1
2A	Silencer	179555	2	22	Needle Bearing	96441	1
3	Handle	149201	1	23	Cam Roller Plate	175263	1
4	Pin	149202	1	24	Cam Roller	175265	2
5	Trigger	149204	1	25	Thrust Washer	175266	1
6A	Gasket	149205	1	26	Roller Bearing	175267	1
6	Ball Bearing	112062	1	27	Thrust Washer	175268	1
7	Rear End Plate	149206	1	28	Torque Adjust Spring	175269	1
8	Rotor Blade	147473	5	29	Spring Housing	175270	1
9	Rotor	149207	1	30	Retainer Ring	175271	1
10	Cylinder	149209	1	31	Ball Bearing	112027	1
10A	Roller Pin	149208	2	32	Drive Spindle	175273	1
11	Front End Plate	149210	1	33	Nose Housing	175274	1
12	Ball Bearing	141852	1	34	Steel Ball	175275	2
13	Washer	149211	1	35	Clutch Pressure Pin	175276	4
14	Planet Gear	149217	6	36	Torque Adjusting Cap	175277	1
15	Gear Cage	149219	2	37	Spring	175278	1
16	Sun Gear	140026	1	38	Retainer Ring	175279	1
17	Internal Gear	149220	1	39	Quick Change Sleeve	175280	1
18	Connection Tube	175257	1	40	Circlip	149236	1
19	Retainer Ring	149223	1				