

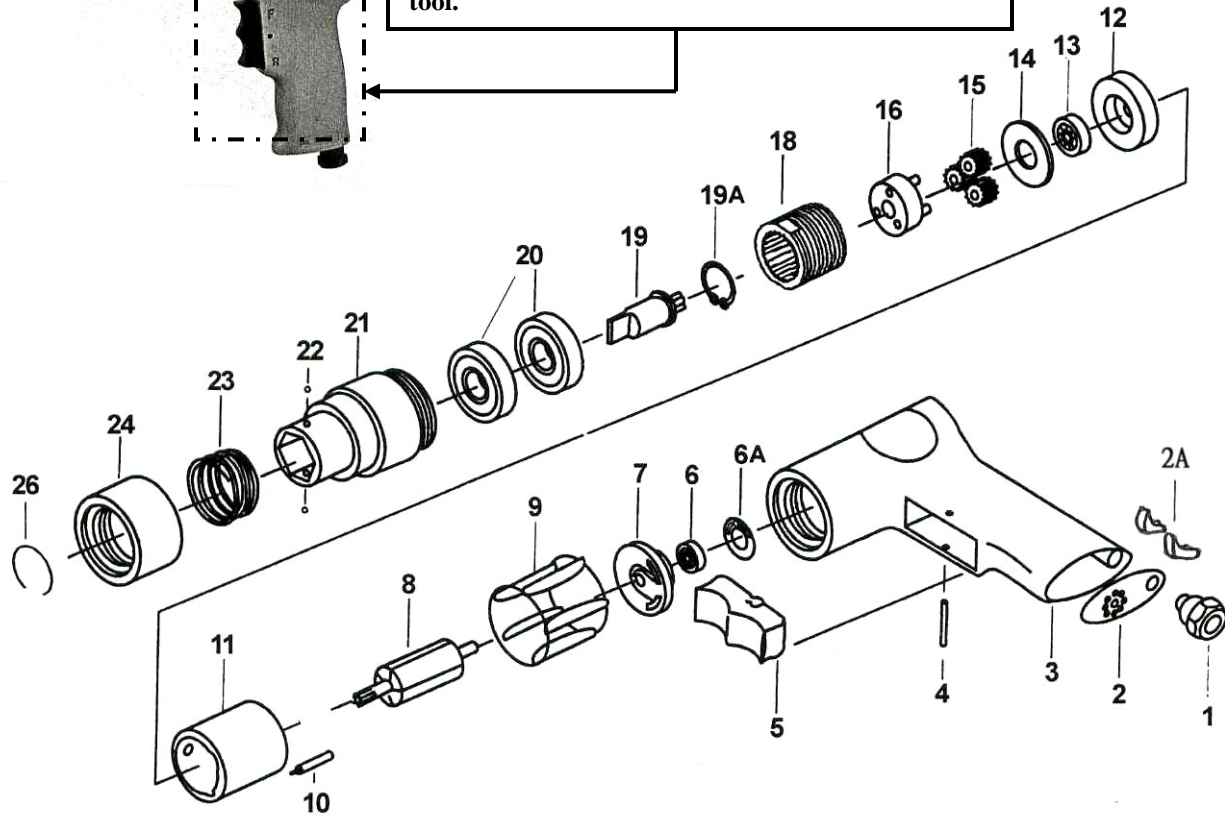

PS1500 PISTOL PULL SETTER

Wespro Pneumatic Tools

DO NOT clamp the handle in a vise or other clamping device ! Also **DO NOT** stamp the aluminum handle body anywhere with letter or number stamps. In doing so, the valve box can be fractured thus requiring a new handle. If marking is required, it should be done with an engraving tool.



* Handle Assembly 152513
(Include parts #1, 2, 2A, 3, 4, 5)

<u>No.</u>	<u>Description</u>	<u>Order Code</u>	<u>Qty</u>	<u>No.</u>	<u>Description</u>	<u>Order Code</u>	<u>Qty</u>
1	Air Inlet	148378	1	13	Ball Bearing	112054	1
2	Diffuser Exhaust	149200	1	14	Washer	149211	1
2A	Silencer	179555	2	15	Planet Gear	149286	3
3	Handle	149201	1	16	Gear Cage	149287	1
4	Pin	149202	1	18	Internal Gear	149288	1
5	Trigger	149204	1	19A	Retainer Ring	149223	1
6A	Gasket	149205	1	19	Drive Spindle	149227	1
6	Ball Bearing	112062	1	20	Ball Bearing	112042	2
7	Rear End Plate	149206	1	21	Nose Housing	149289	1
8	Rotor	149253	1	22	Ball	149228	2
9	Rotor Blade	147473	5	23	Spring	149232	1
10	Roller Pin	149208	2	24	Sleeve	149234	1
11	Cylinder	149209	1	26	Circlip	149236	1
12	Front End Plate	149255	1				