

USG-4V,4VL,5V,5VL & 5VLA VERTICAL GRINDERS

EXPLODED VIEW

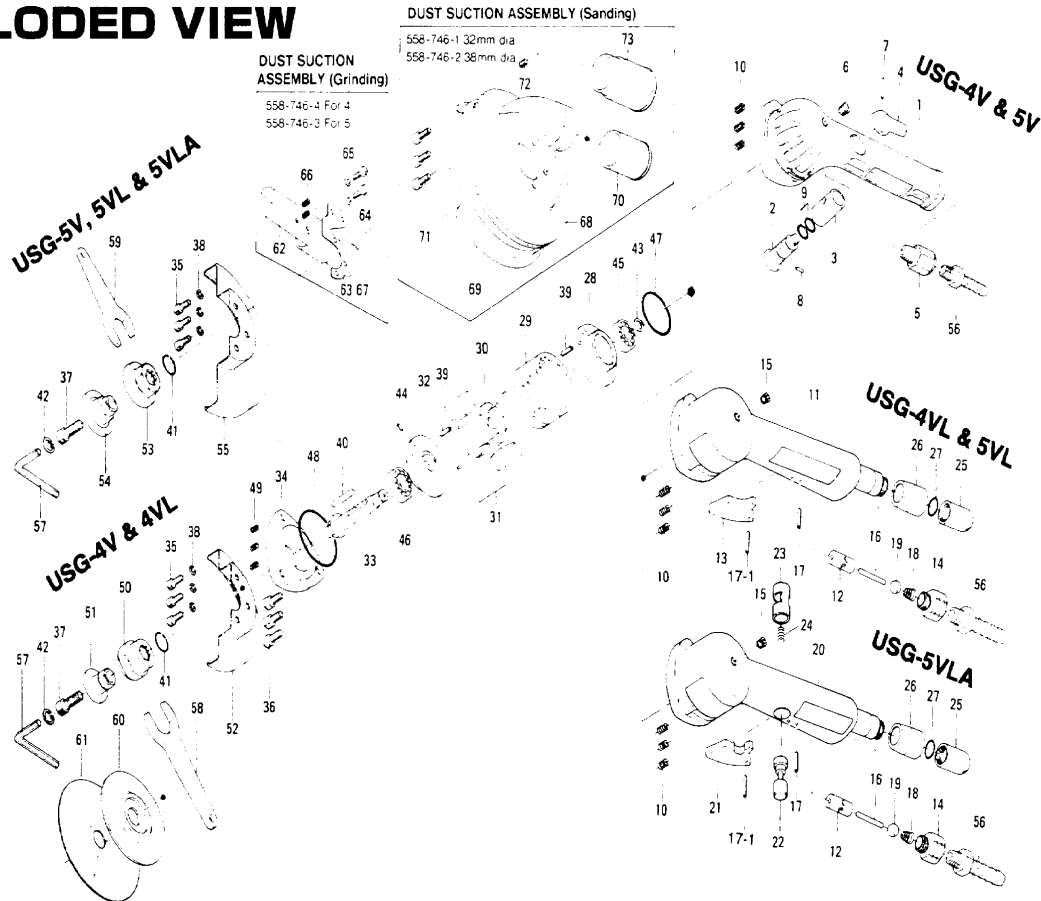

PARTS LIST

Index. No.	Code No.	Parts Name	Quantity	Index. No.	Code No.	Parts Name	Quantity	Index. No.	Code No.	Parts Name	Quantity
555-004-1 CASING ASSEMBLY for USG-4V & 5V				558-004-6 CASING ASSEMBLY for USG-4VL & 5VL				558-004-9 CASING ASSEMBLY for USG-5VLA			
#	1	555-025-1	1	#	11	558-025-6	1	#	20	558-025-9	1
#	2	555-100-1	1	#	12	063-102-1	1	#	12	063-102-1	1
#	3	555-101-1	1	#	13	085-107-1	1	#	21	558-107-9	1
#	4	555-107-1	1	#	14	185-091-7	1	#	22	558-146-9	1
#	5	942-114-0	1	#	15	966-022-0	1	#	23	558-147-9	1
#	6	966-022-0	1	#	16	970-337-0	1	#	24	976-079-0	1
#	7	971-120-0	1	#	17	973-122-0	1	#	14	185-091-7	1
#	8	973-006-0	1	#	17-1	973-120-0	1	#	15	966-022-0	1
#	9	990-008-0	2	#	18	977-220-0	1	#	16	970-337-0	1
#	10	965-020-0	3	#	19	981-210-0	1	#	17	973-122-0	1
558-004-6 CASING ASSEMBLY for USG-4VL & 5VL				#	10	965-020-0	3	#	17-1	973-120-0	1
#	11	558-025-6	1	#	20	558-025-9	1	#	18	977-220-0	1
#	12	063-102-1	1	#	12	063-102-1	1	#	19	981-210-0	1
#	13	085-107-1	1	#	13	085-107-1	1	#	10	965-020-0	3
#	14	185-091-7	1	#	14	185-091-7	1	558-004-9 CASING ASSEMBLY for USG-5VLA			
#	15	966-022-0	1	#	15	966-022-0	1	#	20	558-025-9	1
#	16	970-337-0	1	#	16	970-337-0	1	#	12	063-102-1	1
#	17	973-122-0	1	#	17	973-122-0	1	#	21	558-107-9	1
#	17-1	973-120-0	1	#	17-1	973-120-0	1	#	22	558-146-9	1
#	18	977-220-0	1	#	18	977-220-0	1	#	23	558-147-9	1
#	19	981-210-0	1	#	19	981-210-0	1	#	24	976-079-0	1
#	10	965-020-0	3	#	10	965-020-0	3	#	14	185-091-7	1
558-004-9 CASING ASSEMBLY for USG-5VLA				#	14	185-091-7	1	#	15	966-022-0	1
#	20	558-025-9	1	#	15	966-022-0	1	#	16	970-337-0	1
#	12	063-102-1	1	#	16	970-337-0	1	#	17	973-122-0	1
#	21	558-107-9	1	#	17	973-122-0	1	#	17-1	973-120-0	1
#	22	558-146-9	1	#	17-1	973-120-0	1	#	18	977-220-0	1
#	23	558-147-9	1	#	18	977-220-0	1	#	19	981-210-0	1
#	24	976-079-0	1	#	19	981-210-0	1	#	10	965-020-0	3
#	14	185-091-7	1	#	10	965-020-0	3	558-004-6 CASING ASSEMBLY for USG-4VL & 5VL			
#	15	966-022-0	1	558-004-6 CASING ASSEMBLY for USG-4VL & 5VL				#	11	558-025-6	1
#	16	970-337-0	1	#	11	558-025-6	1	#	12	063-102-1	1
#	17	973-122-0	1	#	12	063-102-1	1	#	13	085-107-1	1
#	17-1	973-120-0	1	#	13	085-107-1	1	#	14	185-091-7	1
#	18	977-220-0	1	#	14	185-091-7	1	#	15	966-022-0	1
#	19	981-210-0	1	#	15	966-022-0	1	#	16	970-337-0	1
#	10	965-020-0	3	#	16	970-337-0	1	#	17	973-122-0	1
558-004-6 CASING ASSEMBLY for USG-4VL & 5VL				#	17	973-122-0	1	#	17-1	973-120-0	1
#	11	558-025-6	1	#	17-1	973-120-0	1	558-004-9 CASING ASSEMBLY for USG-5VLA			
#	12	063-102-1	1	#	18	977-220-0	1	#	20	558-025-9	1
#	13	085-107-1	1	#	18	977-220-0	1	#	12	063-102-1	1
#	14	185-091-7	1	#	19	981-210-0	1	#	21	558-107-9	1
#	15	966-022-0	1	#	10	965-020-0	3	#	22	558-146-9	1
#	16	970-337-0	1	#	10	965-020-0	3	#	23	558-147-9	1
#	17	973-122-0	1	558-004-9 CASING ASSEMBLY for USG-5VLA				#	24	976-079-0	1
#	17-1	973-120-0	1	#	20	558-025-9	1	#	14	185-091-7	1
#	18	977-220-0	1	#	21	558-107-9	1	#	15	966-022-0	1
#	19	981-210-0	1	#	22	558-146-9	1	#	16	970-337-0	1
#	10	965-020-0	3	#	23	558-147-9	1	#	17	973-122-0	1
558-004-9 CASING ASSEMBLY for USG-5VLA				#	24	976-079-0	1	#	17-1	973-120-0	1
#	20	558-025-9	1	#	12	063-102-1	1	#	18	977-220-0	1
#	12	063-102-1	1	#	13	085-107-1	1	#	19	981-210-0	1
#	21	558-107-9	1	#	14	185-091-7	1	#	10	965-020-0	3
#	22	558-146-9	1	#	15	966-022-0	1	558-004-6 CASING ASSEMBLY for USG-4VL & 5VL			
#	23	558-147-9	1	#	16	970-337-0	1	#	11	558-025-6	1
#	24	976-079-0	1	#	17	973-122-0	1	#	12	063-102-1	1
#	14	185-091-7	1	#	17-1	973-120-0	1	#	13	085-107-1	1
#	15	966-022-0	1	#	18	977-220-0	1	#	14	185-091-7	1
#	16	970-337-0	1	#	19	981-210-0	1	#	15	966-022-0	1
#	17	973-122-0	1	#	10	965-020-0	3	#	16	970-337-0	1
#	17-1	973-120-0	1	#	10	965-020-0	3	#	17	973-122-0	1
#	18	977-220-0	1	558-004-6 CASING ASSEMBLY for USG-4VL & 5VL				#	17-1	973-120-0	1
#	19	981-210-0	1	#	11	558-025-6	1	#	18	977-220-0	1
#	10	965-020-0	3	#	12	063-102-1	1	#	19	981-210-0	1
558-004-6 CASING ASSEMBLY for USG-4VL & 5VL				#	13	085-107-1	1	#	10	965-020-0	3
#	11	558-025-6	1	#	14	185-091-7	1	558-004-9 CASING ASSEMBLY for USG-5VLA			
#	12	063-102-1	1	#	15	966-022-0	1	#	20	558-025-9	1
#	13	085-107-1	1	#	16	970-337-0	1	#	12	063-102-1	1
#	14	185-091-7	1	#	17	973-122-0	1	#	21	558-107-9	1
#	15	966-022-0	1	#	17-1	973-120-0	1	#	22	558-146-9	1
#	16	970-337-0	1	#	18	977-220-0	1	#	23	558-147-9	1
#	17	973-122-0	1	#	19	981-210-0	1	#	24	976-079-0	1
#	17-1	973-120-0	1	#	10	965-020-0	3	#	14	185-091-7	1
#	18	977-220-0	1	#	10	965-020-0	3	#	15	966-022-0	1
#	19	981-210-0	1	558-004-9 CASING ASSEMBLY for USG-5VLA				#	16	970-337-0	1
#	10	965-020-0	3	#	20	558-025-9	1	#	17	973-122-0	1
558-004-9 CASING ASSEMBLY for USG-5VLA				#	21	558-107-9	1	#	17-1	973-120-0	1
#	20	558-025-9	1	#	22	558-146-9	1	#	18	977-220-0	1
#	12	063-102-1	1	#	23	558-147-9	1	#	19	981-210-0	1
#	21	558-107-9	1	#	24	976-079-0	1	#	10	965-020-0	3
#	22	558-146-9	1	558-004-6 CASING ASSEMBLY for USG-4VL & 5VL				#	11	558-025-6	1
#	23	558-147-9	1	#	11	558-025-6	1	#	12	063-102-1	1
#	24	976-079-0	1	#	12	063-102-1	1	#	13	085-107-1	1
#	14	185-091-7	1	#	13	085-107-1	1	#	14	185-091-7	1
#	15	966-022-0	1	#	14	185-091-7	1	#	15	966-022-0	1
#	16	970-337-0	1	#	15	966-022-0	1	#	16	970-337-0	1
#	17	973-122-0	1	#	16	970-337-0	1	#	17	973-122-0	1
#	17-1	973-120-0	1	#	17	973-122-0	1	#	17-1	973-120-0	1
#	18	977-220-0	1	#	17-1	973-120-0	1	#	18	977-220-0	1
#	19	981-210-0	1	#	18	977-220-0	1	#	19	981-210-0	1
#	10	965-020-0	3	#	19	981-210-0	1	#	10	965-020-0	3
558-004-6 CASING ASSEMBLY for USG-4VL & 5VL				#	10	965-020-0	3	558-004-9 CASING ASSEMBLY for USG-5VLA			
#	11	558-025-6	1	#	20	558-025-9	1	#	20	558-025-9	1
#	12	063-102-1	1	#	21	558-107-9	1	#	12	063-102-1	1
#	13	085-107-1	1	#	22	558-146-9	1	#	21	558-107-9	1
#	14	185-091-7	1	#	23	558-147-9	1	#	22	558-146-9	1
#	15	966-022-0	1	#	24	976-079-0	1	#	23	558-147-9	1
#	16	970-337-0	1	558-004-9 CASING ASSEMBLY for USG-5VLA				#	24	976-079-0	1
#	17	973-122-0	1	#	20	558-025-9	1	#	12	063-102-1	1
#	17-1	973-120-0	1	#	21	558-107-9	1	#	21	558-107-9	1
#	18	977-220-0	1	#	22	558-146-9	1	#	22	558-146-9	1
#	19	981-210-0	1	#	23	558-147-9	1	#	23	558-147-9	1
#	10	965-020-0	3	#	24						